

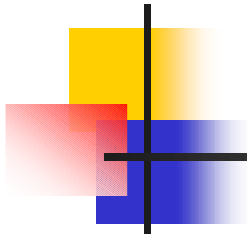

S-72.423 Telecommunication Systems

An Overview to Course Contents



Topics today

- Practicalities
- Table of course contents
- Networking paradigms: Determining networking trends
- Network evolvment
 - Topology
 - divided
 - integrated
 - mobile
 - Telecommunication markets
- Review of course contents in selected topics
 - The OSI-model
 - Networking approaches: PSTN, ISDN, Mobile, Internet
- Future trends



Practicalities

- Lectures
 - Timo Korhonen (timo.korhonen@hut.fi)
 - Michael Hall (michael.hall@hut.fi)
- Tutorials
 - Mika Nupponen (mika.nupponen@hut.fi)
- Lectures on Thursdays 10-12 in U358
- Tutorials on Tuesdays 14-16 in E111
- Textbooks: Ericsson, Telia: Understanding Telecommunications, Part II, ISBN 91-44-00214-9, W. Stallings: Data and Computer Communications, ISBN 0-13-571274-2
- Homepage: <http://www.comlab.hut.fi/opetus/423>



Course contents

- Introduction
- Public Switched Telephone Network (PSTN)
 - Exchange techniques
 - Transmission
- Integrate Services Digital Network (ISDN)
 - Functions
 - Interfaces
- Automatic Transfer Mode (ATM) and Broadband-ISDN
- X.25, Frame relay
- Public land mobile networks
 - GSM
 - WCDMA
- Signaling networks: SS7
- The Internet: Network topology, TCP/IP Suite, Services

Telecommunication networks have much in common

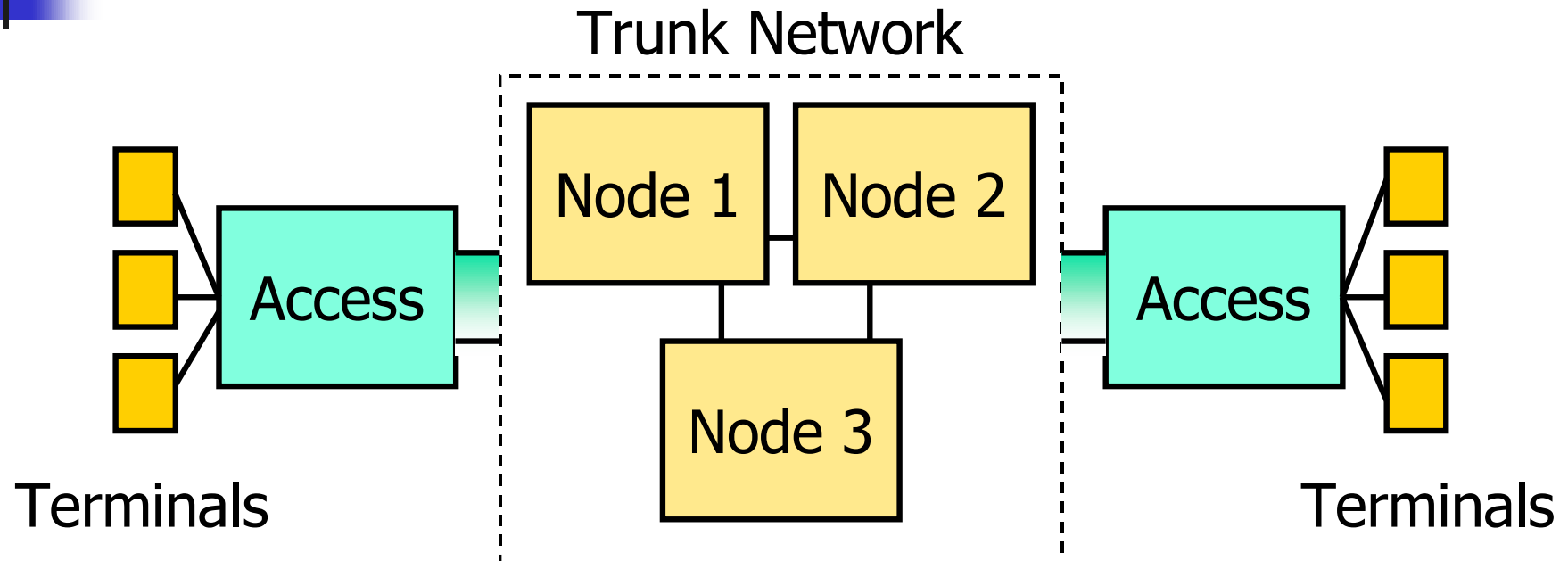

- Trunk and access parts
- Access part terminated by terminals
- Network nodes and links are optimized for certain assumed traffic patterns
- This model applies for both data and voice networks
- Due to these network similarities their analysis carries common subtopics



Course contents: Networking subtopics

- User services and terminals
- Standards
- Routing and switching
- Transmission techniques
- Access and transport
- Server services
- Signaling
- Network management
- Interworking between networks
- Network planning

Paradigm shift

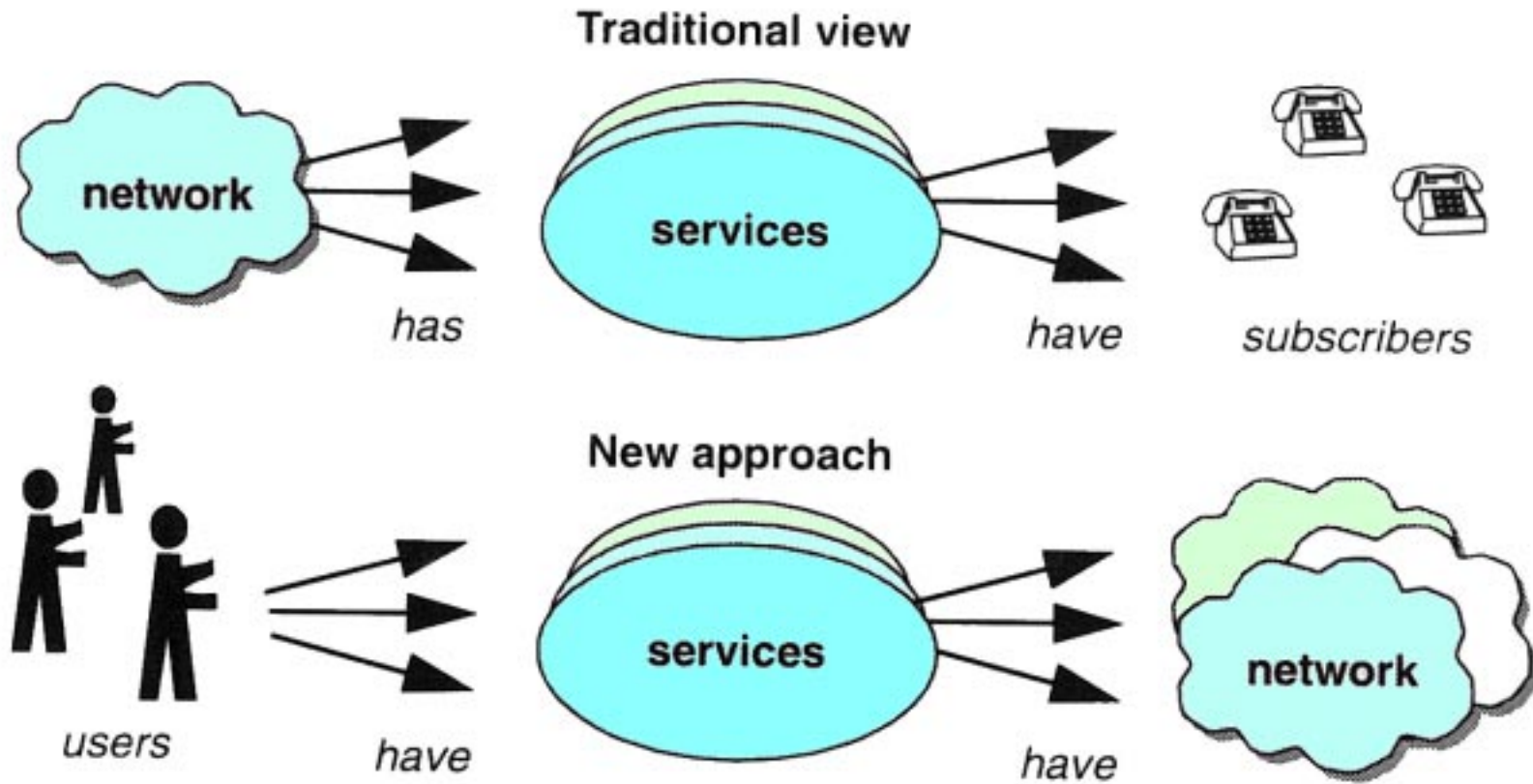

Network evolvment



- Most people observe that a telecommunications network is a system transmitting the messages... In this course we focus on analyzing that it consists of ...

Data and voice networks

Divided networks

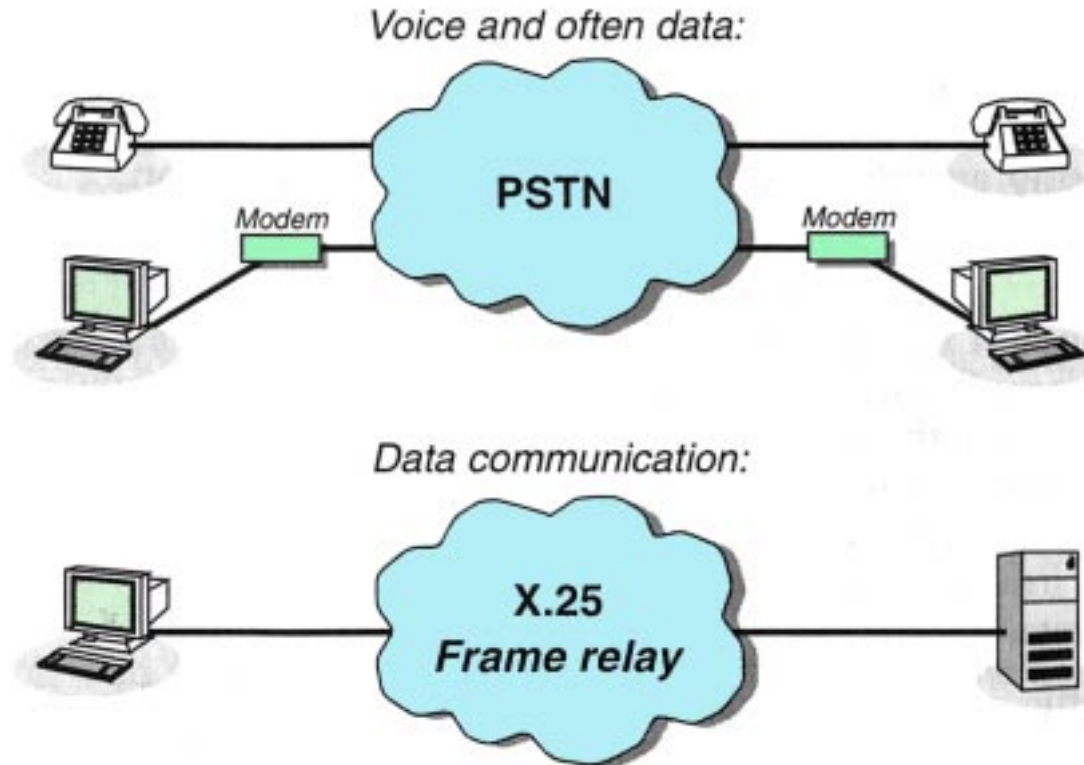

- Nodes and links with well defined (standardized) interfaces
- Network nodes and links that are optimized for certain, assumed traffic
- Traditional assumption: Voice and data services in different networks

Integrated Services Digital Network (ISDN)

Merged networks

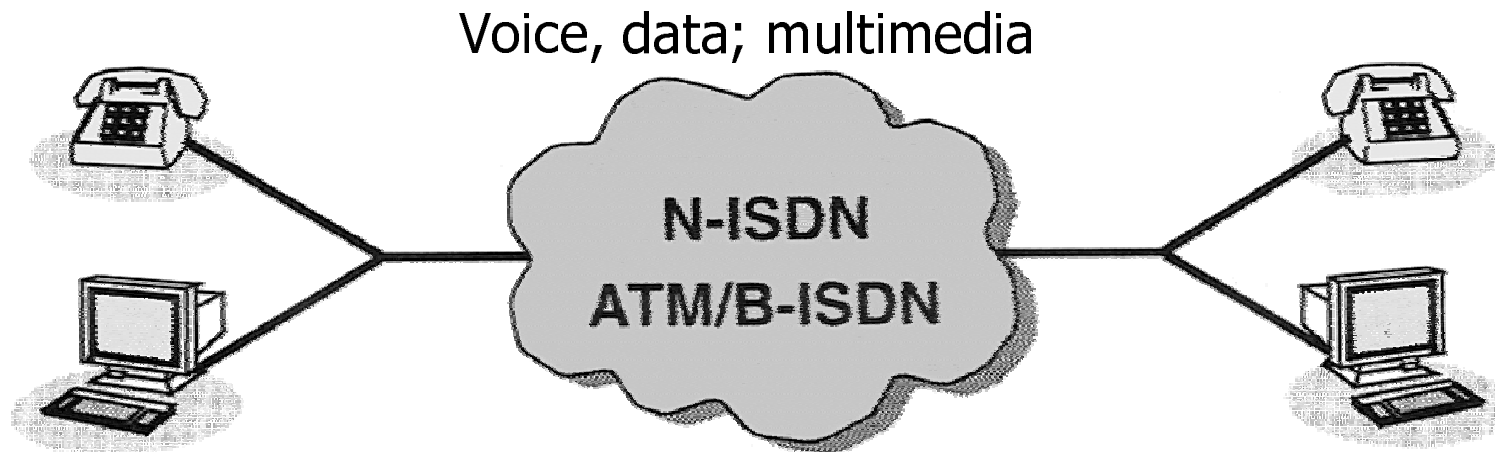

- Modern PSTN exchanges apply ISDN technology (64 kb/s...2 Mb/s) both internally and externally
- ISDN and its broadband version B-ISDN (up to 100Mb/s) support data communications for future PLMNs
- Data divided now into constant rate, real-time and higher-latency data

ATM: Asynchronous Transfer Mode PLMN: Public Land Mobile Network

Network/service adaptivity

- Services manifest themselves via various customer profiles (that differ within a short time period), and thus efficient adaptivity should be supported by network configurations
- Advanced networks *have a tendency* carry intelligence in terminals (and not in exchanges)
 - Reduces signaling traffic
 - Moves costs to end-users
- IN (Intelligent Network) solutions developed first for PSTN but a typical important part of most networks as in PLMNs
 - Enables service flexibility in exchanges
 - IN services designed in cooperation with terminal intelligence

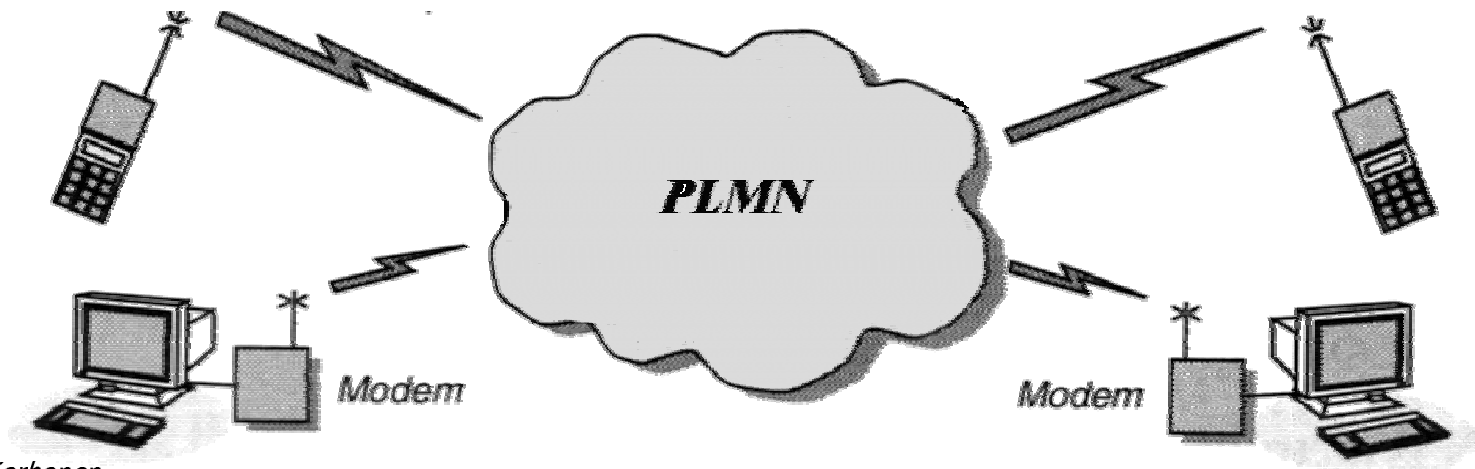



Public Land Mobile Networks (PLMN)

Merged mobile IP networks

- Mobility is required practically for all services in the very near future!
- In this course we will discuss especially the GSM (Global System for Mobile communications) (9.6 kbit/s) and WCDMA (Wideband Code Division Multiple Access) networks
- After 2002 WCDMA will be launched that will yield mobile data rates up to 3Mb/s. However, also the GSM network will be upgraded for higher rates thanks to
 - GPRS (General Packet Switched Data),
 - HSCSD (High Speed Circuit Switched Data) and
 - EDGE (Enhanced Data Rates for GSM Evolution)

Telecomm market players

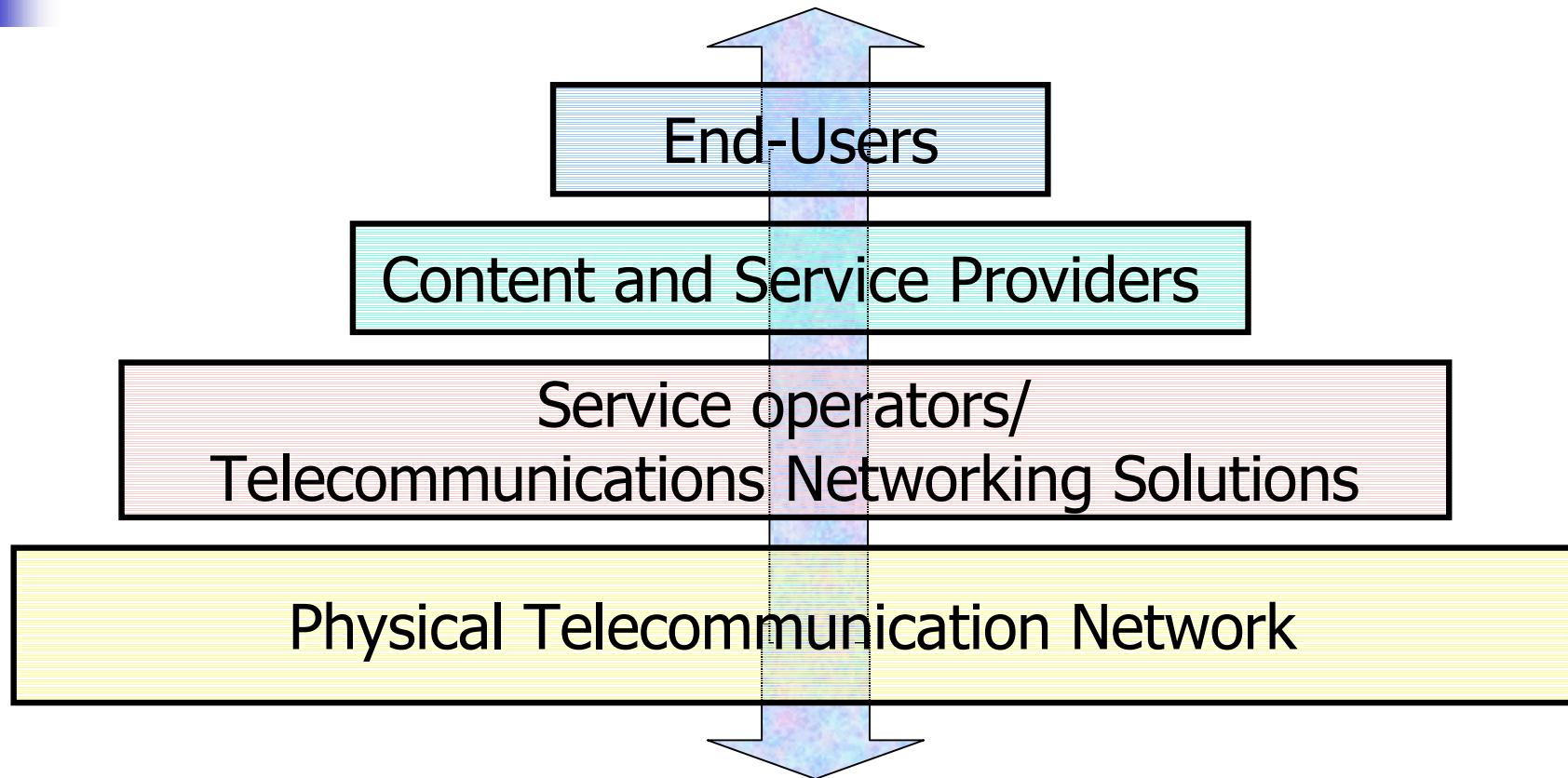

- Telecommunication network content and technology producers, operators and consumers form a hierarchy

Telecomm market players (example)

- **End-users** (individuals and companies)
- Information **service providers** (As a telephone catalog services designed by a company, giving telephone numbers when you give a name or an address)
- **Service brokers** sell dedicated service packages
- Network **operators** (as HPY, Telia, or Radiolinja)
- **Content providers** (as Paramount Pictures)

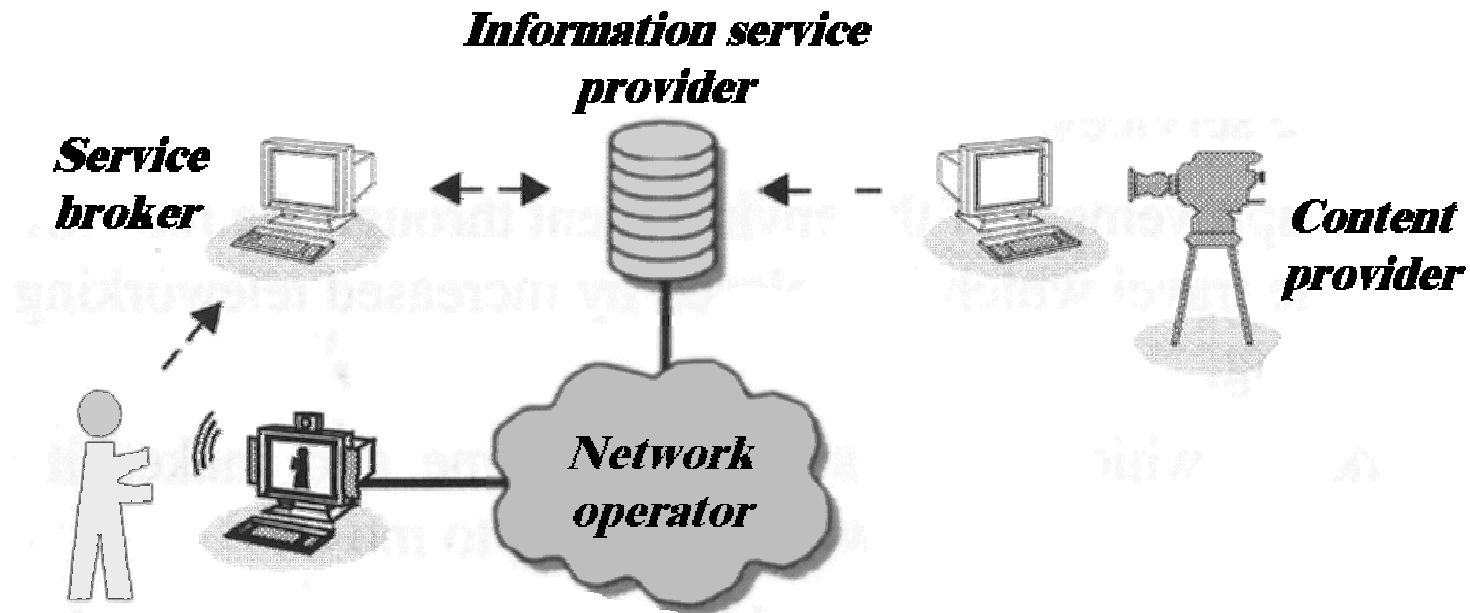



Telecom services categorized

Category	Important application
Communications	teleworking, multimedia, mail
Knowledge	distance education, database retrievals
Entertainment	games etc. (getting more and more important!)
Information	Marketing, yellow pages, catalogues
Service	Telemedicine, home shopping and banking
Remote control/remote supervision	Automation applications

The ISO-OSI Model

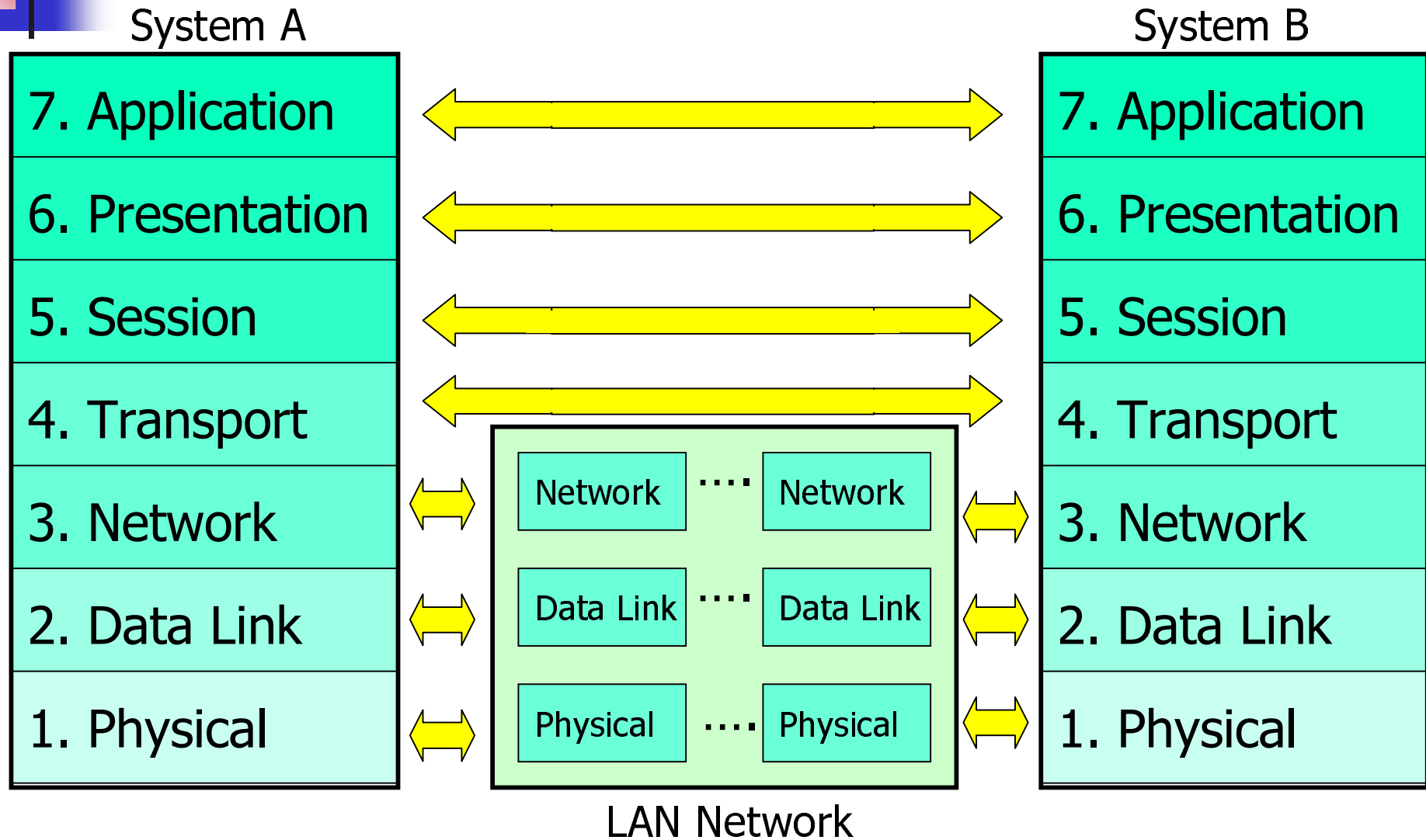

OSI: Open System Interconnections
ISO: International Organization for Standardization



The OSI-functions

7. Application	User <u>access</u> to OSI environment applications
6. Presentation	Provides <u>independence</u> of applications from differences in data presentations
5. Session	Establishing, managing and termination <u>connections</u> (sessions) between cooperating applications
4. Transport	Provides reliable, <u>transparent</u> data transfer for lower level <u>data segments or blocks</u>
3. Network	Gives <u>routing</u> service for transport layer. Layer of <u>routers</u> .
2. Data Link	Sends data block with synchronization, error and flow control for <u>end-to-end connections*</u> . Layer of <u>bridges</u> .
1. Physical	Transforms electrical signal into bits. In local networks standardized by 802.x standard. Layer or <u>repeaters</u>

Gateway Layers

LAN Layers

*For instance in a classroom of workstations
HUT Comms. Lab, Timo O. Korhonen

Practical networks usually melt OSI

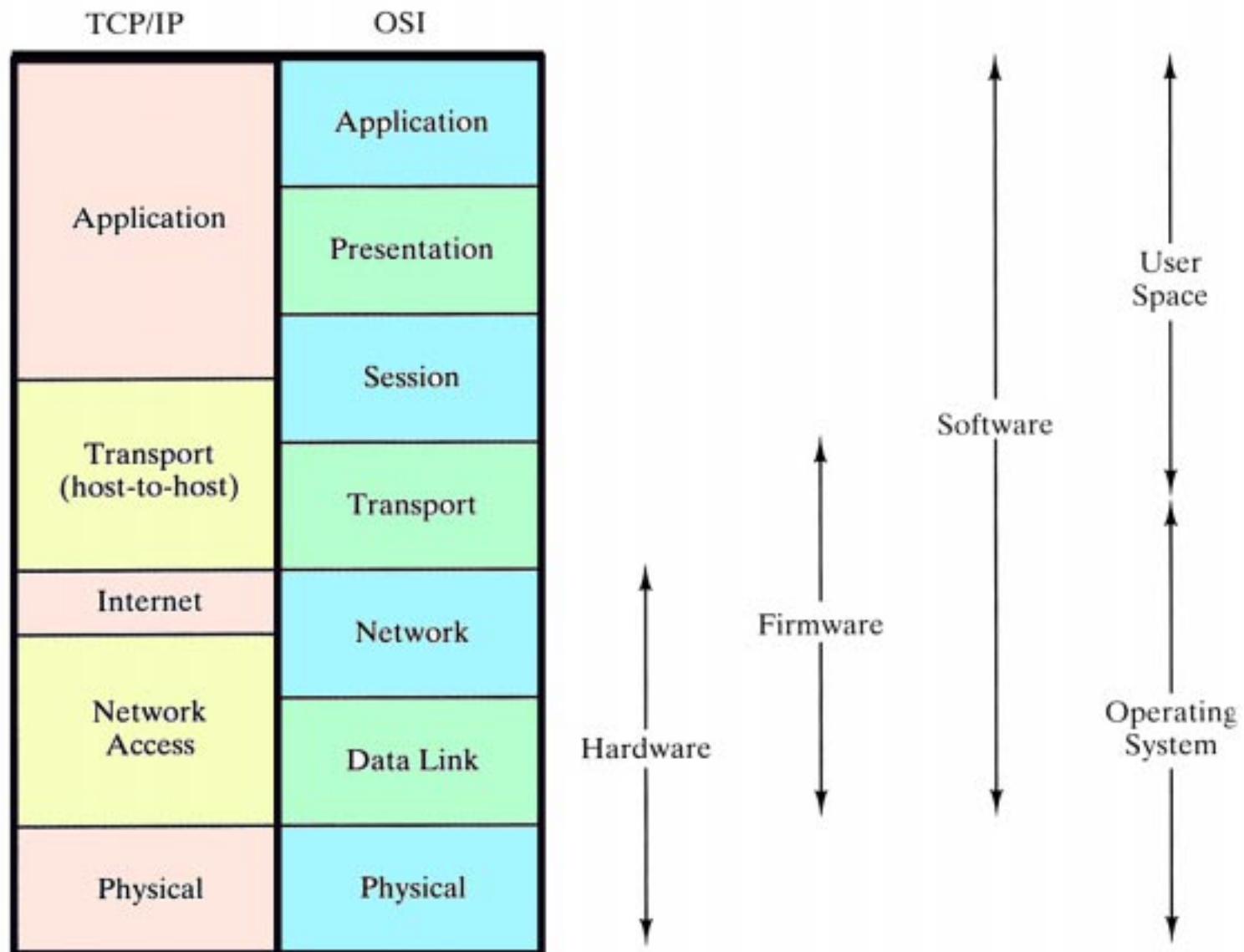



Each OSI-layer has its standardized services

7. Application	NCP, FTP, Telnet, SMTP, SNMP, LAT, AFP, SMB...
6. Presentation	SNA Presentation services
5. Session	NetBIOS, NetBEUI, DNS, ...
4. Transport	SPX, PEP, TCP, UDP, NSP...
3. Network	IPX, RIP, SAP, IDP, IP, ARP, RARP, ICMP, X.25, RIP...
2. Data Link	IEEE 802.X, ANSI X3T9.5, SMT,...
1. Physical	V.24, V.35, V.90, 10Base5, 10Base2, 10BaseT, FDDI, SDH, G.703...

Practical network stratum

- OSI is seldom realized as itself but several layers are melted together into stratum
- In this example X.25 packet network operates on ATM based SDH access stratum.
- ATM forms an efficient info pipe where no address checking or error correction is done but it is left for lower layers

LAN/MAN/WAN
"layer"

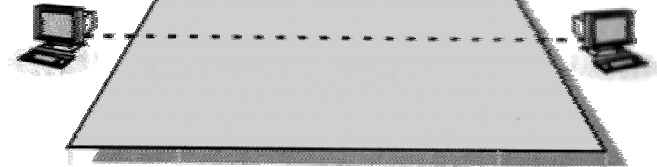

X.25 "layer"

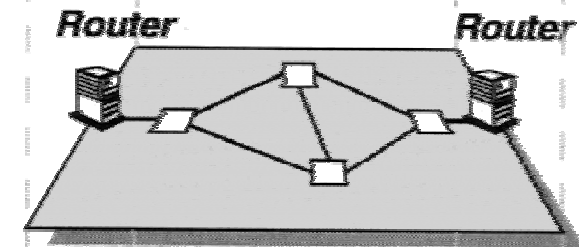

ATM "layer"

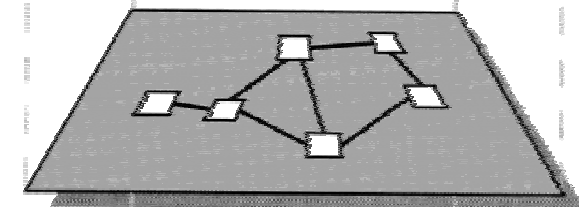

SDH/Physical
"layer"

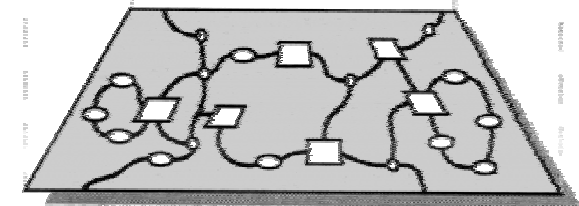

The PSTN hierarchy

- Since '96 in Finland all the exchanges of PSTN have been digital
- However, there exists still analog phones
- Natural connection to the modern PSTN is the ISDN-interface

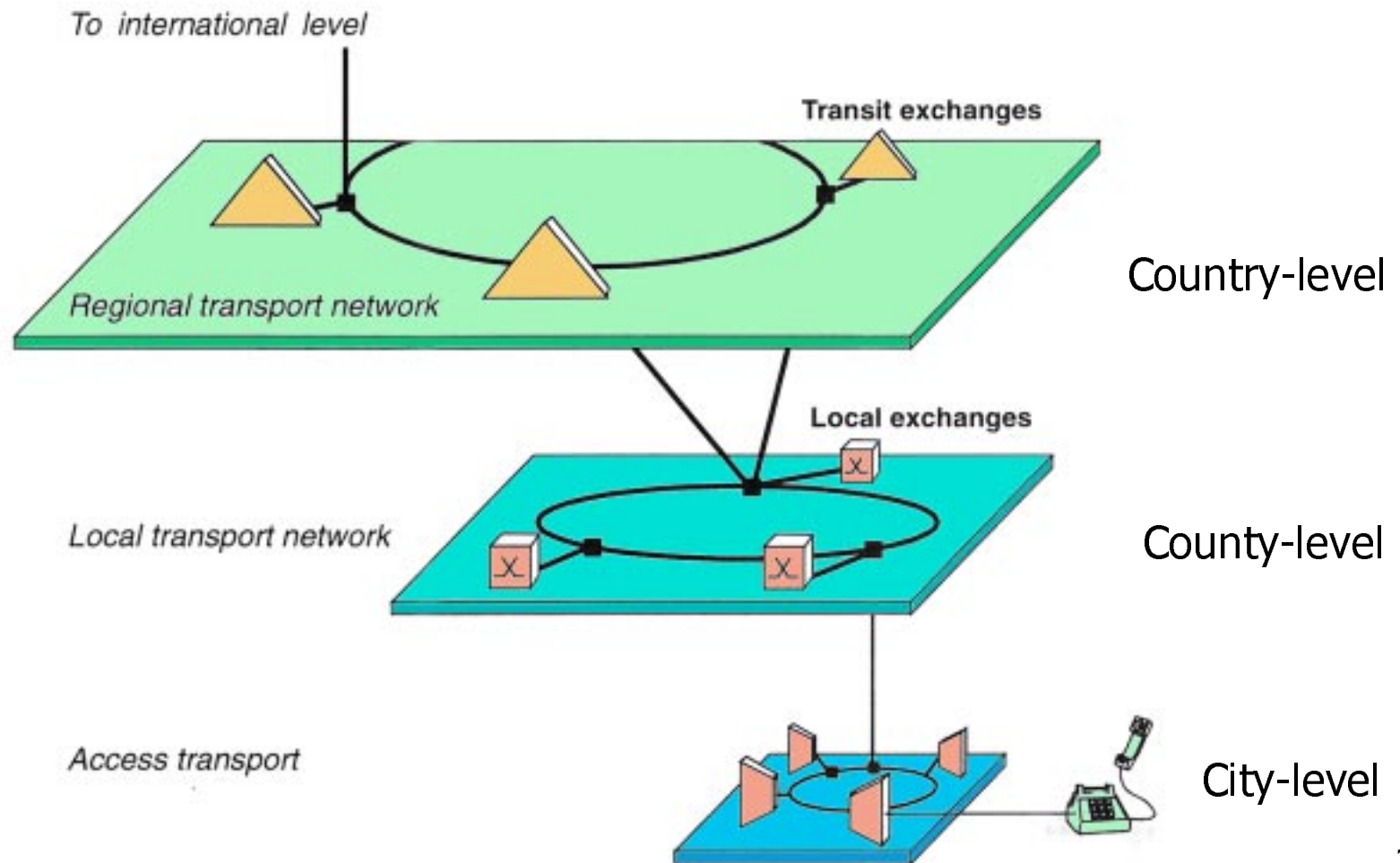

Example: PSTN Network operator in two towns

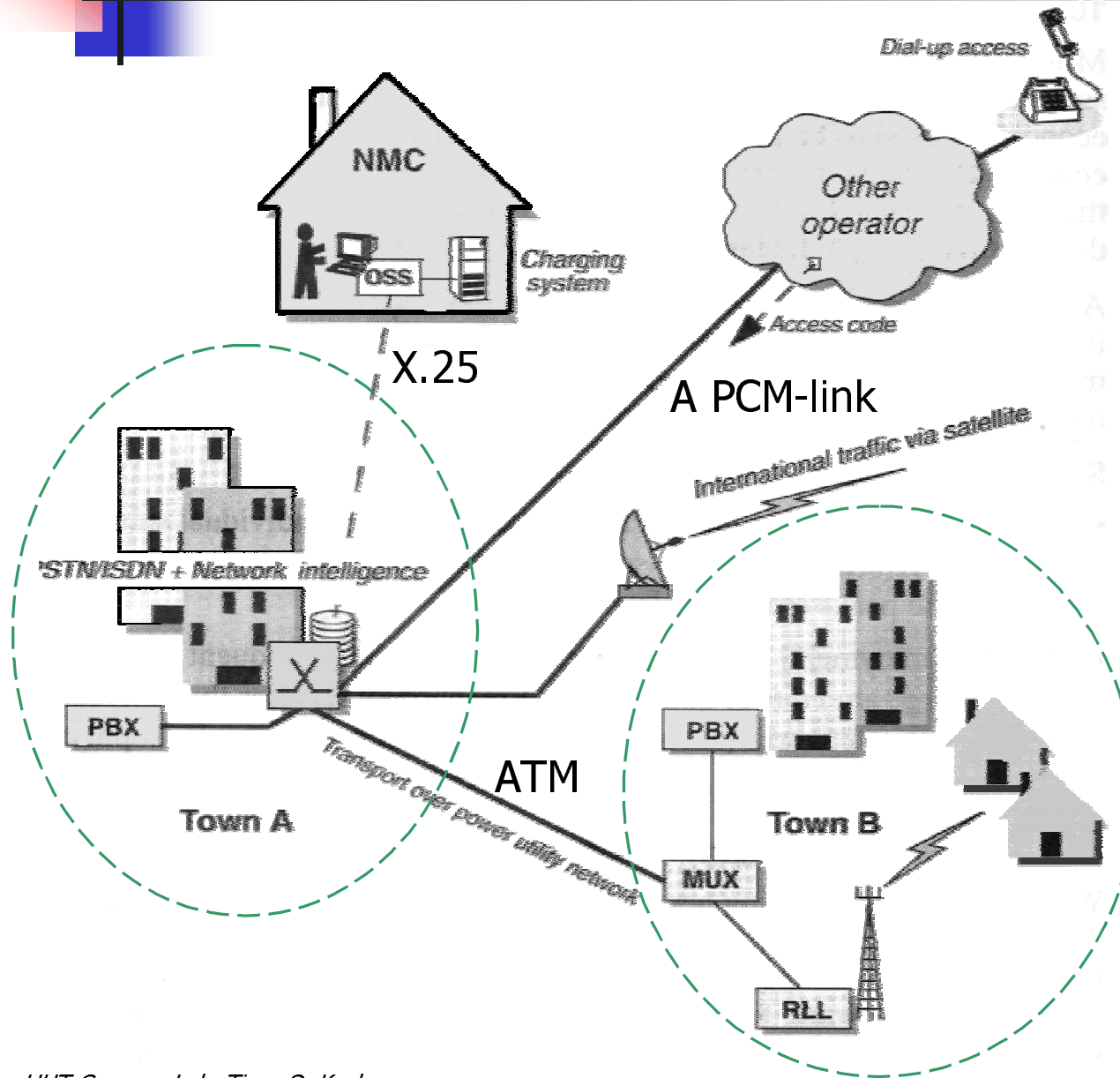

Note that by *dial-up networking* part of local exchange capacity is allocated for another operator

- OSS: Operations Support System
- NMC: Network Maintenance Center
- RLL: Radio in the Local Loop
- MUX: multiplexer
- PBX: Private Branch Exchange



Telecommunications service requirements from the physical level

- Networking requirements: What services require from the network in respect of
 - Bandwidth,
 - Burstiness,
 - Symmetry (uplink /downlink rates),
 - Bit errors and blocking
 - Delay
 - Security
- These define QOS (Quality of Service)

Different services require different rates

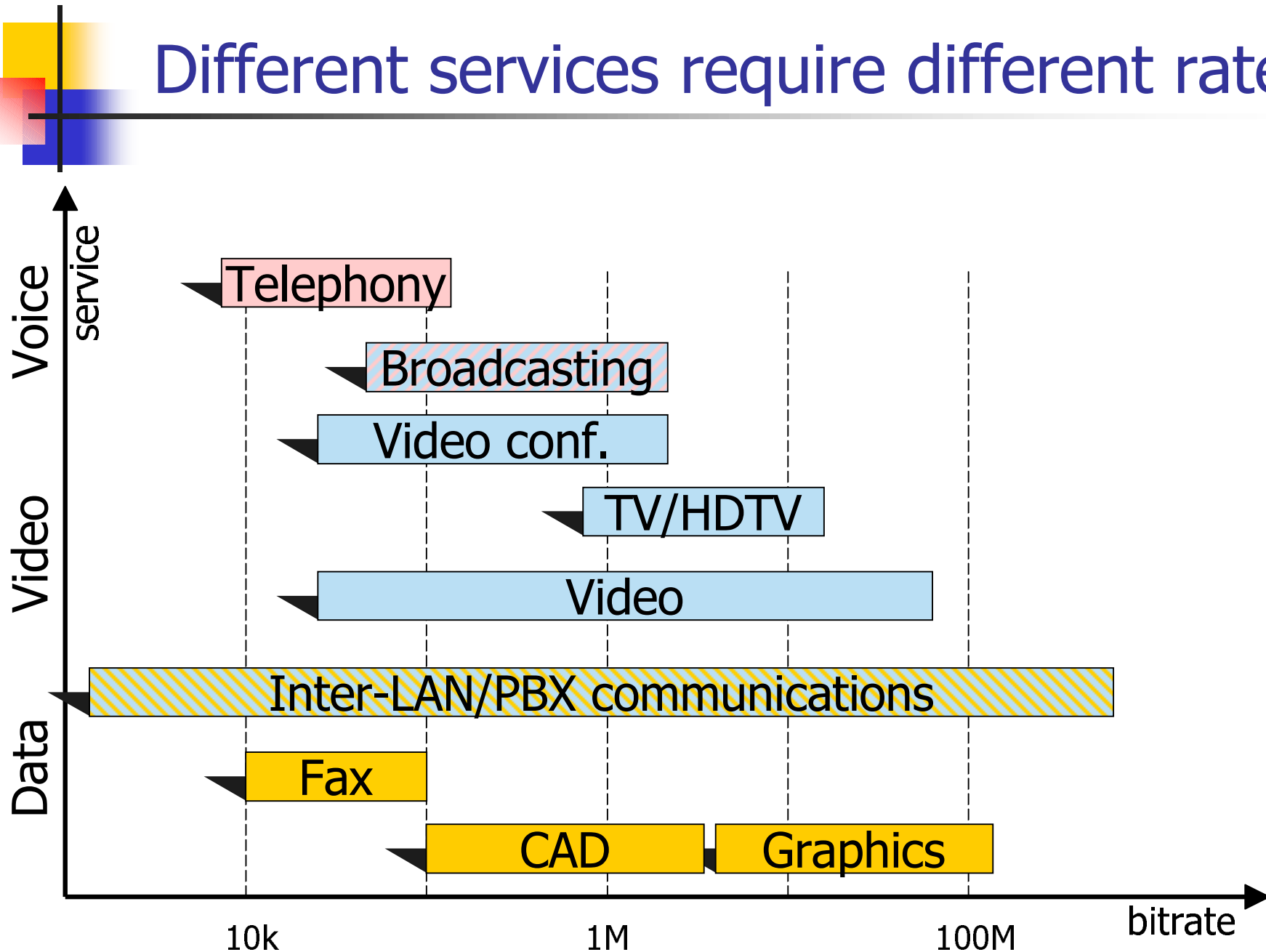

Burstiness: video, voice, data

- Different services (telecomm. traffic) require different networking abilities
- Most real-life sources produce bursty traffic
- Modern networks can adapt into bursty service by allocation capacity very rapidly for other users

Bursty traffic:

- Human speech
- Video and multimedia sources
- Data bursts in a packet network

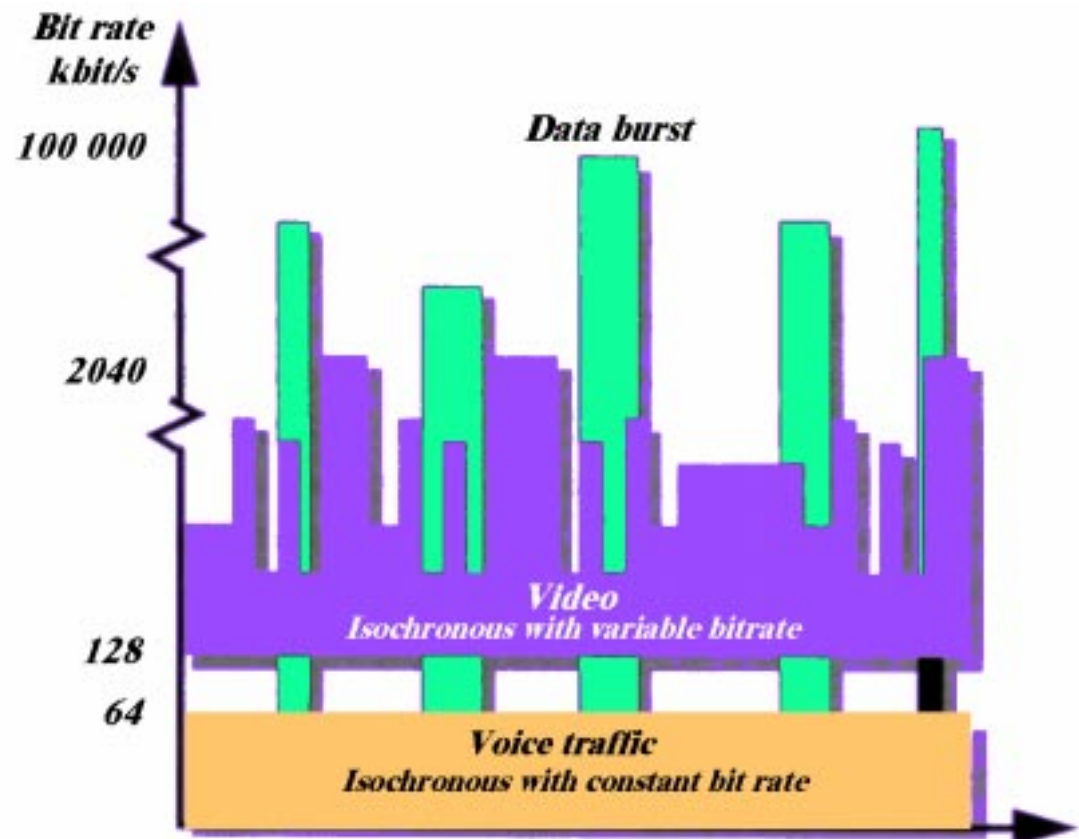



Speech and data communications

	Speech	Data
Delays	Limited to ~200 ms	Depends on Data
Errors	High tolerance	Very limited tolerance
Stream	Continuous: Circuit switching	Bursty: Packet switching

- Teletraffic can be forced to fixed rate or bandwidth as speech in PSTN or ATM traffic



Bit errors and blocking

- Real-time services for video and audio
 - Can not tolerate delays clearly observable by human (in order 200 ms or larger)
 - Can tolerate relatively large error rates
 - Blocking probability depends on number of customers in a service area
- Fixed rate data services require much non-reusable capacity:
 - Fixed delay
 - demanding error rate limit
- High-latency data:
 - Large flexibility in delay
 - demanding error rate limit



Symmetry

- Categories:
 - **Symmetrical channel** as in fixed line telephony
 - **Asymmetrical channel**
 - Most technical Internet realizations (As xDSL-techniques or data over DVB) are based on idea that downlink traffic is order of magnitude larger than uplink traffic
 - **Point-to-multipoint** channel
 - TV and Fax are point-to-multipoint distributive services
- Note, however that some new services in Internet (where your PC works as a server, as Napster) might require symmetrical traffic channel
- Also Internet is used for point-to-multipoint services as in Webcasting (as in Web-broadcasting or in the PointCast news service.)
- Therefore developing Internet services set stringent requirements for network planning!



Security and secrecy

- Services might require security, e. g. reliable, shielded transfer:
 - rescue services
 - police
 - defence force
 - some special applications as telesurgery
- Networks can provide this by using:
 - fixed lines (PSTN)
 - flexible routing (SS7)
 - scrambling or encryption
 - coding
- Often secrecy is reassured in several network levels



Public switched telephone network (PSTN)

- The oldest (1876) bearer network (other: ISDN, ATM, frame relay, The Internet)
- After 1960 has got many renovations: data, fax, processor exchanges, PCM, satellite communications, network intelligence
- Primary characteristics
 - Analog access 300-3400 Hz
 - Circuit switched connection
 - Switched bandwidth 64 kbit/s (Digital exchanges)
 - Immobility (or very limited mobility)
 - Integrated nowadays especially with N-ISDN



The PSTN (cont.)

- The PSTN is optimized for **statistically** distributed, analog speech subscribers (by using the circuit switching technology that was available beginning of this century).
- Support for data traffic "artificially added" by
 - modems
 - ISDN (integrated into exchanges)
 - xDSL (asynchronous digital subscriber line)
- However, PSTN is
 - Easily congested when subscriber behavior changes unexpectedly (no graceful degradation as in CDMA-PLMN): resource wasting



The PSTN (cont.)

- Vulnerable: network paralyzed easily in exchange malfunctions
- Network intelligence in exchanges and dummy terminals
- Poor adaptivity
- However, an important backbone for other networks!
- The PSTN will be there for a long time and it seems that it can be used for modern day networking also on quite high data rates of order of several Mbytes by using various extension techniques
- Modern day networks are constructed thus that the required services can be supported: Thus

Services shape the modern networks!



Integrated Services Data Network (ISDN)

- In N-ISDN (narrow band 2×64 kb/s +16 kb/s, extendable up to $30 \times 64 = 1.92$ Mb/s), B-ISDN (rates exceeding 100 Mb/s) and ATM (asynchronous transfer mode) networks all services are handled integrated, circuit switched way.
- Mobility enabled by DECT (Digital Enhanced Cordless Telecommunications)
- Nowadays there exists many competitive techniques for ISDN as
 - Cable modems,
 - ISM -band (Industry, Science, Medicine) LANs (as the HiperLAN)
 - Digital satellite networking by DVB (SAS Astra)
 - WCDMA
 - PSTN with 56 kbit/s (V.90) technology

Signaling networks

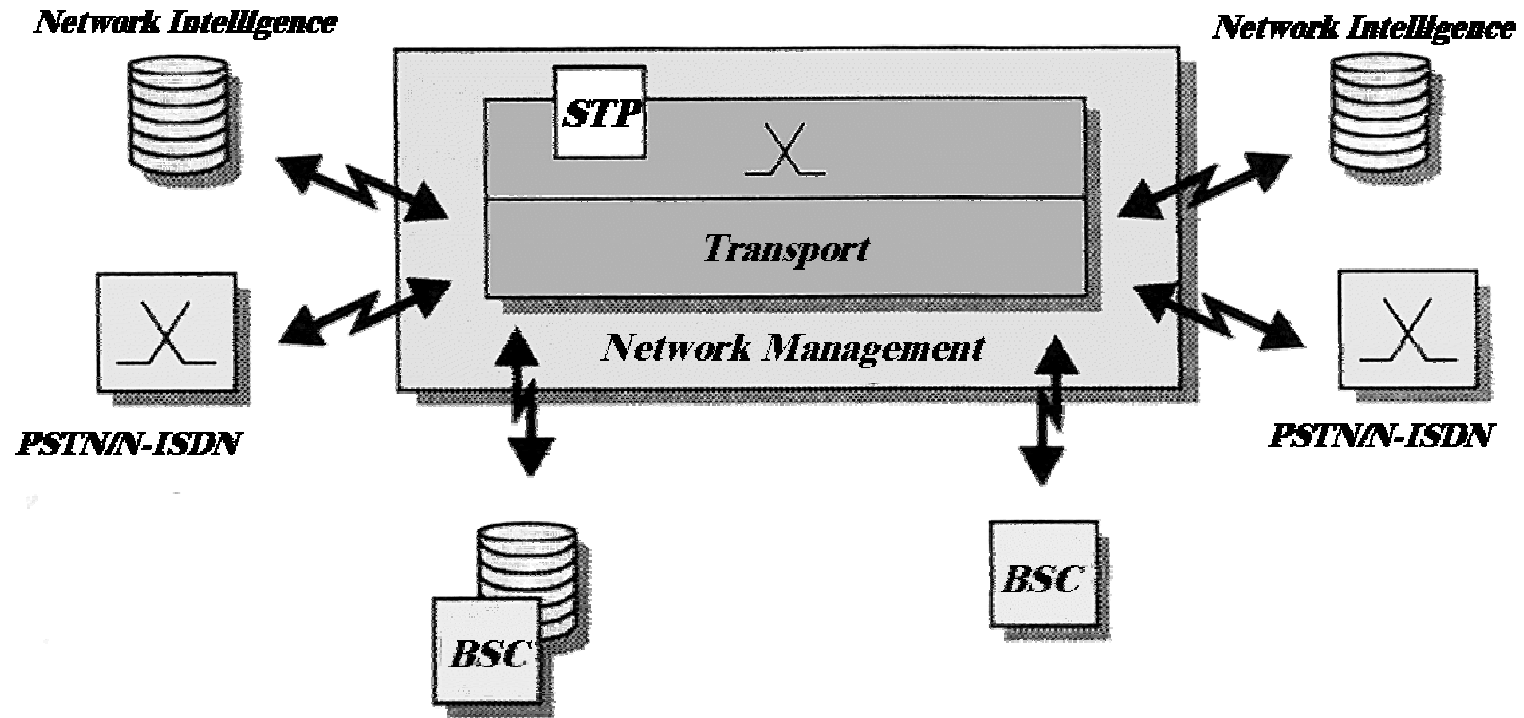

- Telecom nets require more and more processor capacity:
 - More subscribers
 - Setting up connection is getting increasingly complex
 - Number of supplementary services increasing
- Thus the need to transmit signaling information (=interactive network telematic communication) is increasing

The Internet (*working*)

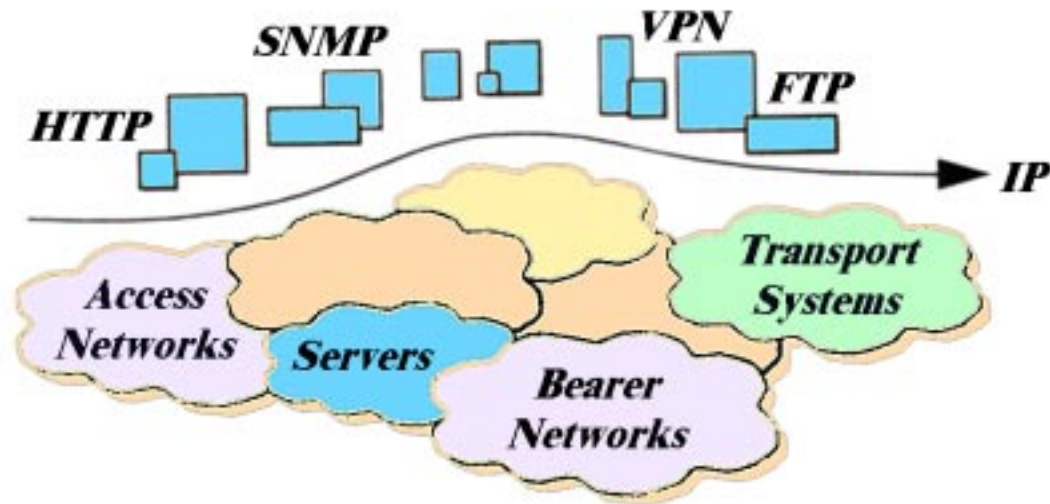

- The Internet carries "Everything over anything" (almost)
- Internet topics:
 - TCP/IP: Frames and sessions
 - Routing: Backbone connected subnets
 - Network planning: Core - Regional nets - Access nets - Users
 - Signaling: TCP client – server communications
 - Services: http, ftp, email, irc, new, telnet
 - Internetworking (!) for instance data over PSTN: PPP, SLIP



TCP/IP: Transmission Control Protocol Internet Protocol

- The first Internet was ARPANET in 1969's with four nodes
- Present TCP/IP version 4 has problems especially in
 - lacking of address capacity
 - security
- In 1997 IPv6 was initiated - However not too much used yet due to compatibility problems
- TCP/IP does not have any general advance (except that it is so widespread) when compared to IPX, AppleTalk, DECnet etc.
- Essential high level network functions
 - routing management
 - name servers
 - network management protocols
- Network consists of
 - hardware as workstations, networks, routers, bridges
 - software as applications and protocols

TCP/IP Network
architecture

TCP/IP Network transmission

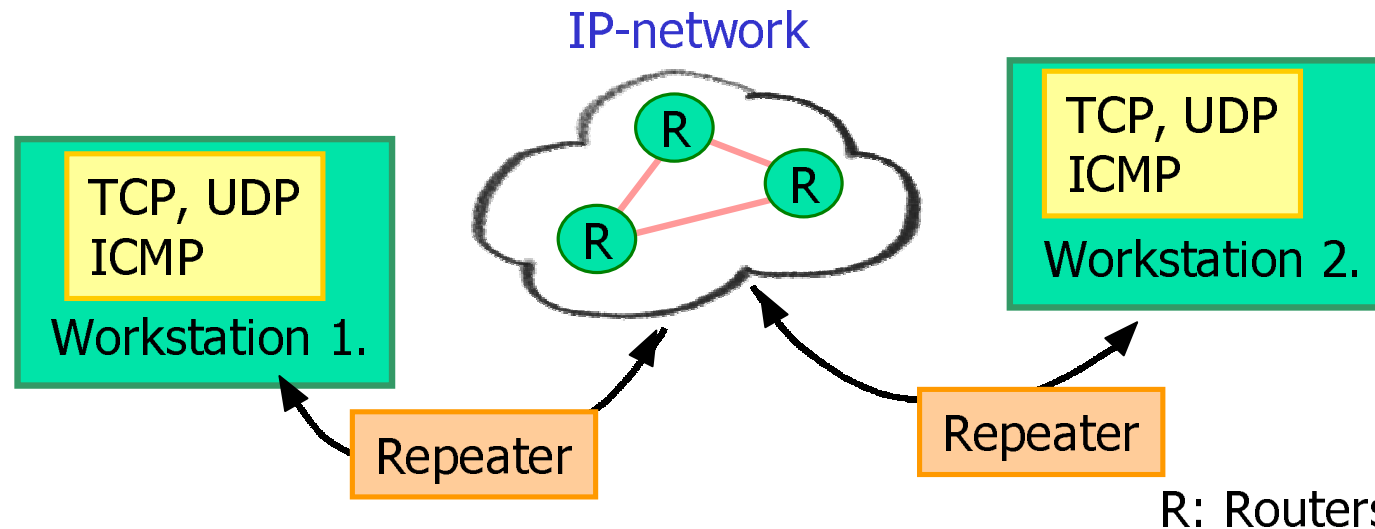

- TPC/IP tasks: end-to-end transmission, error correction, maintain packet order
- Internet is based on datagrams that address subnets via routers
- A simple routing could be accomplished by a lookup table between target IP and subnet IP

UDP: User Datagram Protocol, downgraded TCP/IP for good quality connections
ICMP: Interactive Communication Module Protocol, testing usage

The playground of telecommunications markets

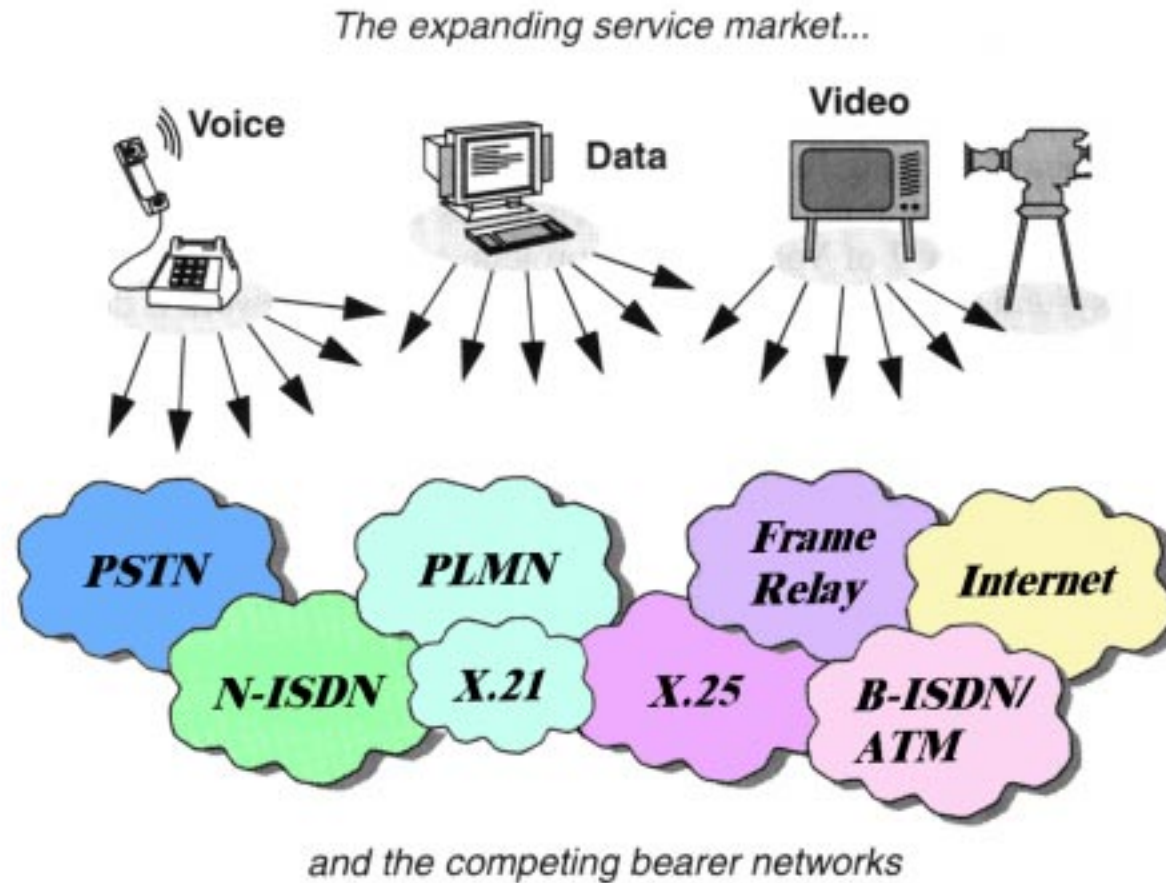

- The expanding service markets and the competing bearer networks form an interesting playground!



Future trends

- PSTN used to transfer more and more data traffic
- PSTN rates increase up to several Mb/s
- Also data networks (as the X.25) will be used for voice and there is a strong tendency to put everything over IP
- The fax service in PSTN will diminish and the respective messages are transmitted by e-mail (that is transferred via a packet networks (usually by TCP/IP))
- Inter(net)working between networks increases
- Traditional voice service in PSTN transforms using packets and moves to Internet
- PLMNs and LANs develop very fast



Web resources

- xDSL: www.adsl.com
- 3:rd generation PLMN: www.w3.org, www.3gpp.org
- Telehallintokeskus: www.thk.fi
- IEEE standards: www.ieee.org
- Finnish standards: www.thk.fi/tele/suomi/standard.htm
- Network & terminal realization: www.nokia.com
- ... and so many more!

Important auxiliary use for abundant abbreviations
is their applicability for Internet search!