

S-72.3340 Optical Networks

Exercise 4

- 1) The optical cross-connect (OXC) node of Figure 1 is designed to cross-connect signals between two incoming and two outgoing fibers, whereby the maximum number of distinct wavelength channels carried per fiber is two (that is, $\lambda_1; \lambda_2$). Produce a sketch showing how the OXC could be scaled to handle three channels ($\lambda_1 \lambda_2 \lambda_3$) per fiber port.

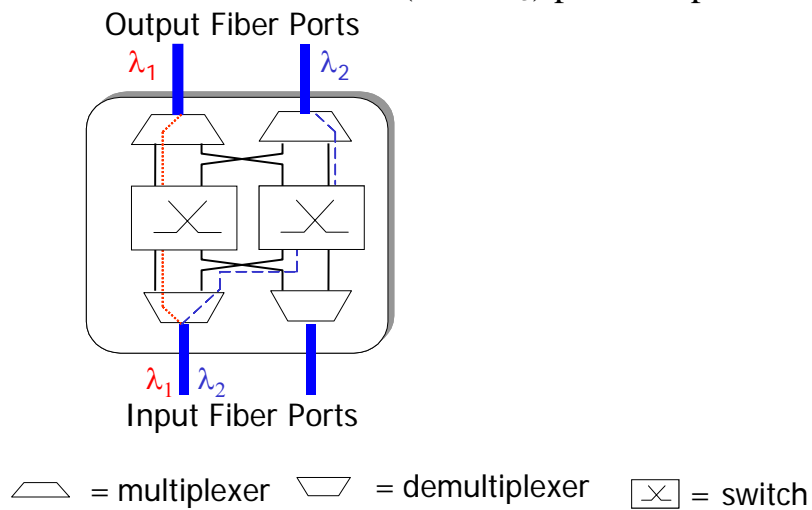

Figure 1 Example OXC with 2 input and 2 output fibers implemented using two 2x2 switches

- 2) A single-fiber unidirectional DWDM optical ring is constructed using reconfigurable OADMs (ROADMs) located at three different sites A, B and C as shown in Figure 2. The traffic between any two sites is carried on single wavelength channels. Currently, traffic between sites A→C, B→C and C→A is carried on channels λ_1 , λ_2 and λ_3 , respectively. However, with all the connections still up, a new request for a connection is made to provide capacity (equivalent to capacity of a single wavelength channel) for data traffic between sites B→A.
- Assuming that there are no wavelength conversion capabilities within the network, show how you can configure the network to handle the extra capacity demand without disrupting any of the existing connections.
 - Repeat the above configuration, this time assuming that full wavelength conversion capabilities are available in all ROADMs.

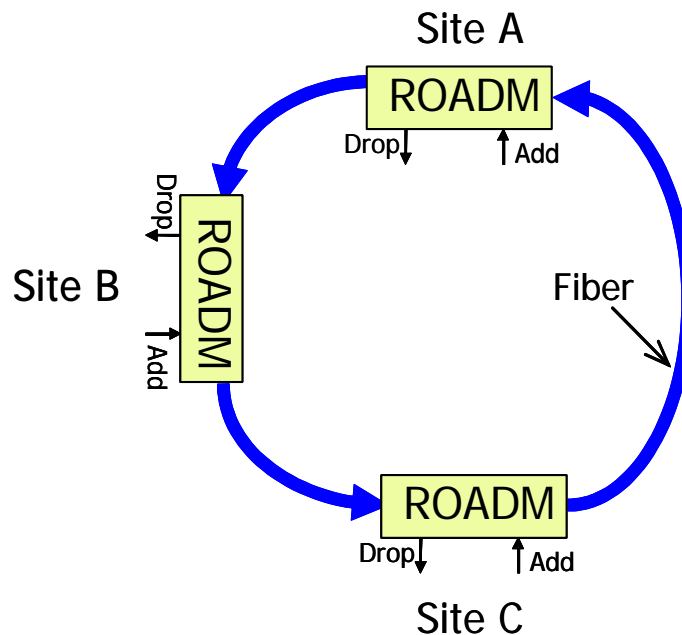

Figure 2 Example three node optical fiber ring