



TKK Tietoliikennelaboratorio  
HUT Communications Laboratory



# **S-72.3340 Optical Networks Course**

## **Lecture 5: TDM-Based Networks**

Edward Mutafungwa  
Communications Laboratory, Helsinki University of Technology,  
P. O. Box 2300, FIN-02015 TKK, Finland  
Tel: +358 9 451 2318, E-mail: [edward.mutafungwa@tkk.fi](mailto:edward.mutafungwa@tkk.fi)

# Lecture Outline

---

- ❑ Introduction
- ❑ SDH/SONET
  - Background history
  - PDH
  - Advantages
- ❑ SDH Multiplexing and Framing
- ❑ SDH Layers
- ❑ Network elements and network configuration
- ❑ Conclusion

# 1. Introduction

- ❑ An **optical layer** is considered server layer
  - Provides services to variety of **client layers**
  - Mainly service is provision of **lightpaths** or optical connections
- ❑ This week lectures focus is on client layers of the optical layer

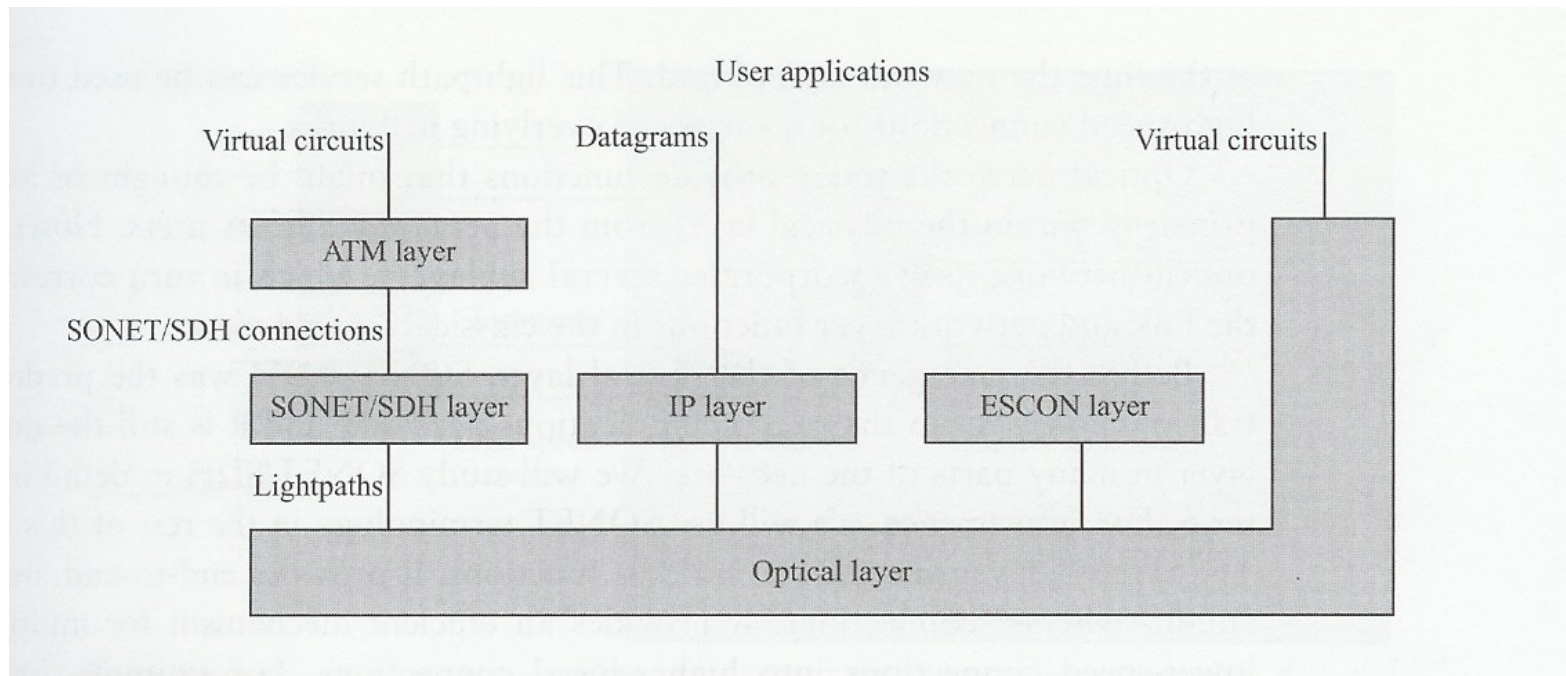
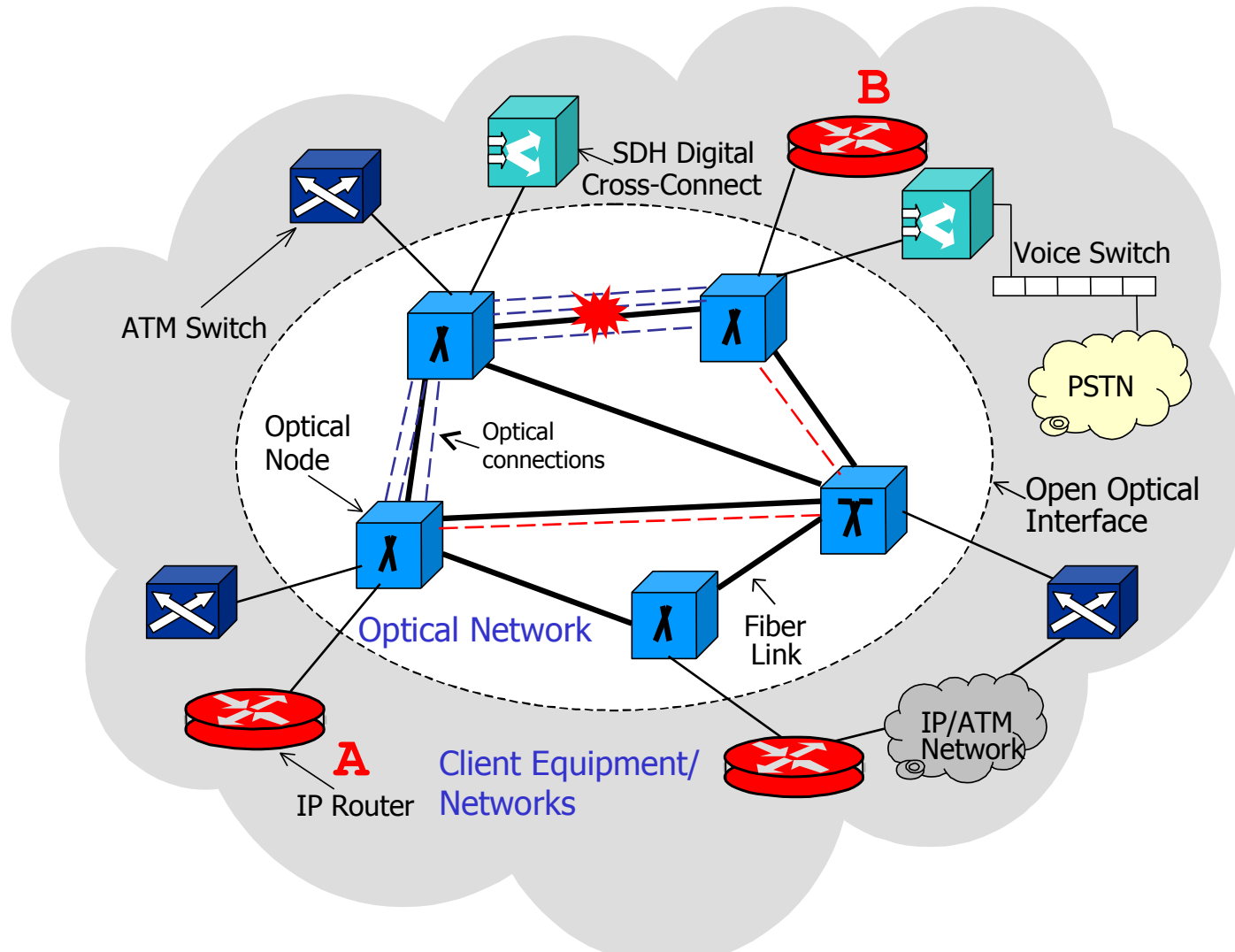

Figure 1.10 A layered view of a network consisting of a second-generation optical network layer that supports a variety of client layers above it.

# 1. Introduction



## 2. Synchronous Digital Hierarchy

---

- ❑ Dominant standard for **optical transmission** and **multiplexing** for high-speed signals
  - **Synchronous Optical Network** (SONET) in North America
    - SONET standardized by Exchange Carrier Standards Association (ECSA, now ATIS) and ANSI in the mid 80s
  - **Synchronous Digital Hierarchy** (SDH) elsewhere
    - SDH standardized by ITU-T in 1988

## 2. Synchronous Digital Hierarchy

---

- ❑ Standardization influenced by two factors
- ❑ Proposals in CCITT (predecessor of ITU–T) for an **Integrated Services Digital Network** (Rec. I.120, 1984)
  - Enable digital transmission of both voice and data over ordinary copper telephone wires
  - ⇒ Necessitated a new, **global multiplexing standard** to support circuit switched data services

# 2. Synchronous Digital Hierarchy

- ❑ The 1984 **breakup of AT&T** into 7 baby Bells (RBOC)
  - Necessitated standardized optical interface between different interexchange carriers
  - Need for new network management features to support new services and centralized control

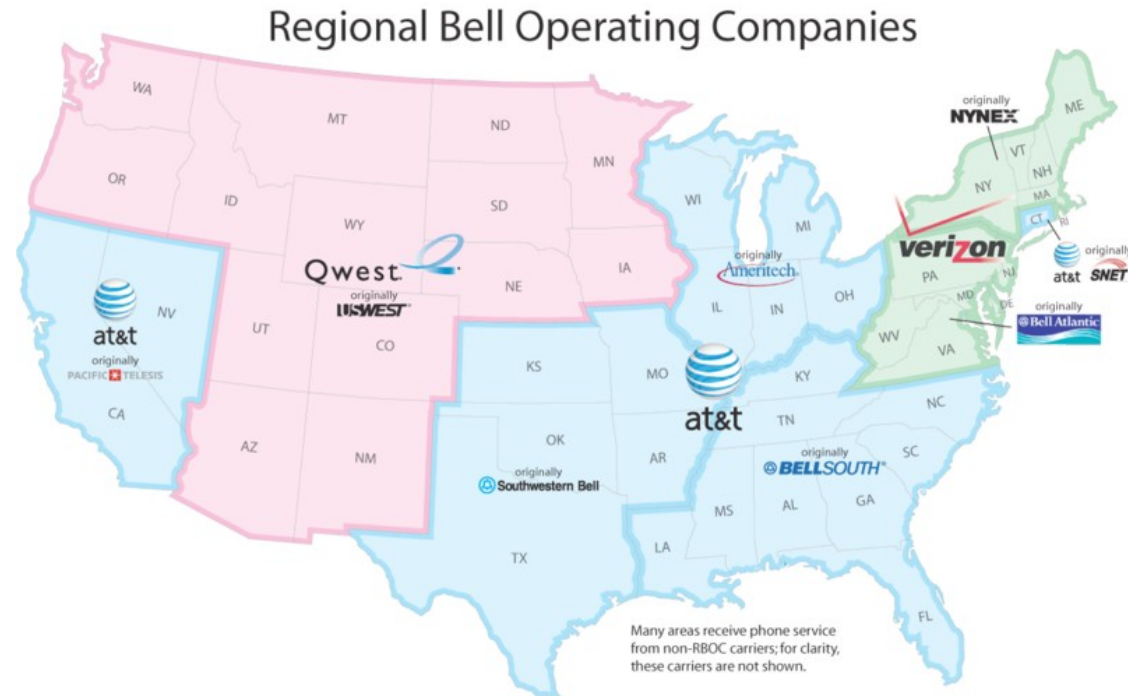

## 2. Synchronous Digital Hierarchy

---

- ❑ SDH and SONET have many similarities
  - Technically consistent with each other
  - Matching line rates
- ❑ SDH and SONET differences
  - Terminologies (nomenclature)
  - Frame format
- ❑ Recommended course book (published in America) concentrates on SONET
- ❑ Emphasis of this course will be on SDH!

# 2.1 Plesiochronous Digital Hierarchy

---

- ❑ **Plesiochronous digital hierarchy** (PDH) came before SDH/SONET
  - Conceived in the mid 1960's
  - Plesiochronous  $\Rightarrow$  from 2 Greek words *plesio* (near) and *chronos* (time)  $\Rightarrow$  almost synchronous
  - Multiplexing standard
  - Early digital transmission over coaxial cables (late 1960s) and fiber-optic links (late 1970s)

## 2.1 Plesiochronous Digital Hierarchy

---

- PDH defined for multiplexing digital **voice circuits**
  - Basic rate of **64 kbit/s** per voice circuit
  - 8 kHz Nyquist sampling rate to convert analog voice signal (30Hz-4kHz) into a digital signal
  - Each sample quantized at 8 bits per sample

$$8000 \text{ samples/seconds} \times 8 \text{ bits/sample} = 64 \text{ kb/s}$$

- Higher-order (faster) streams are **multiples** of the basic 64 kbit/s stream

# 2.1 Plesiochronous Digital Hierarchy

- PDH data streams classified by levels (E0,E1,E2 or E2,E31 or E3,E4) in Europe and (DS0,DS1,DS2,DS3,DS4) in North America ⇒ also uses T1, T2, T3 etc.

**Table 1.1** Traditional DS-n and E-n bit rates of the synchronous hierarchy

Facility	United States	Europe	Japan
DS0/E0	64 kbps	64 kbps	64 kbps
DS1	1,544 kbps		1,544 kbps
E1		2,048 kbps	
DS1c	3,152 kbps		3,152 kbps
DS2	6,312 kbps		6,312 kbps
E22		8,448 kbps	
			32,064 kbps
E31		34,368 kbps	
DS3	44,736 kbps		
DS3c	91,053 kbps		
			97,728 kbps
E4		139,264 kbps	
DS4	274,176 kbps		
			397.2 Mbps

## 2.2 Advantages of SDH over PDH

---

□ SDH offers several advantages over PDH

1. **Multiplexing** ⇒ Difficult to pick out a low bit rate system from PDH multiplexing hierarchy

- Each network terminal runs own clock ⇒ rates between different clocks may differ
- Clocks of multiplexed lower-order streams are not perfectly synchronized (asynchronous)
- Stuff extra **justification bits** into slower streams so that time-division multiplexing can be used
- Stuffing possible by allowing extra bandwidth
  - Example: E3 carries 512 E0 circuits, but E3 rate (34.368 Mb/s) > 512 x E0 rate (64 kb/s)

# 2.2 Advantages of SDH over PDH

- The PDH justification bits make it difficult to identify the start of a lower-order stream within a higher-order one
  - Need to demultiplex to make the identification
  - Might have to go through “DEMUX/MUX-mountain” to extract lower order stream
  - Difficult to lease circuits of lower order streams
  - Unreliable and difficult to detect faults by provider

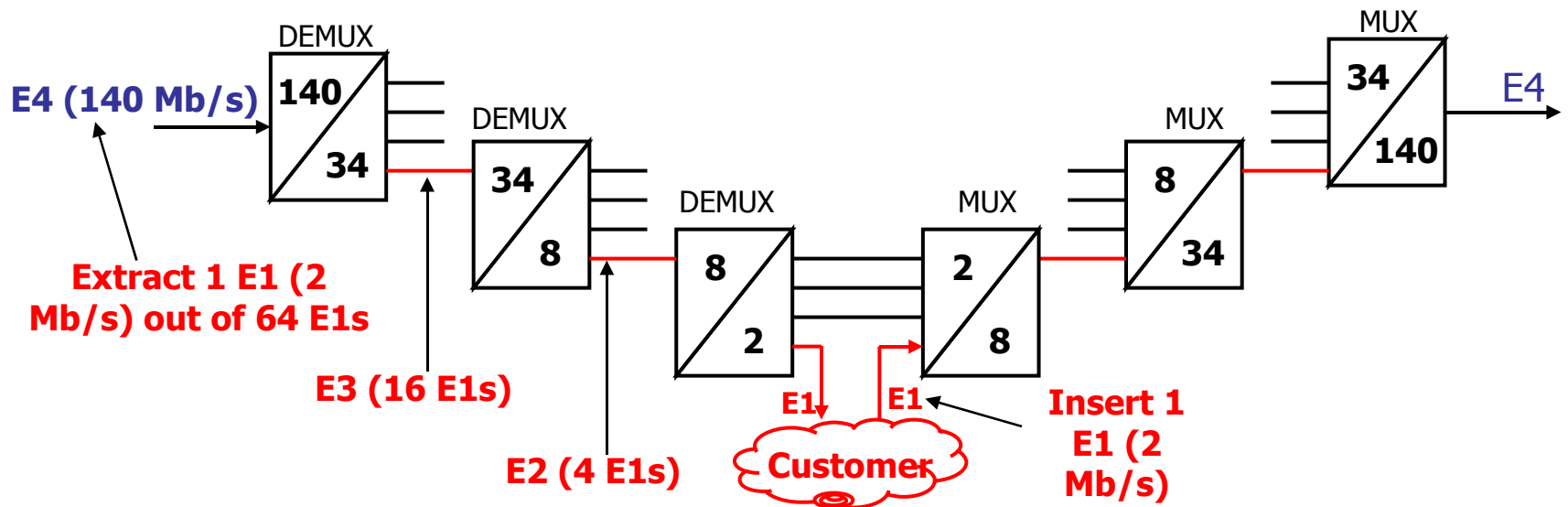

# 2.2 Advantages of SDH over PDH

- ❑ In SDH/SONET networks all clocks are synchronized to single **master clock** ⇒ **synchronous multiplexing**
  - Lower speed stream extracted from SDH/SONET multiplexed stream in a single step by locating appropriate bit positions
  - Easier and cheaper to design SDH/SONET multiplexers and demultiplexers

Lower speed streams a-f



High speed stream

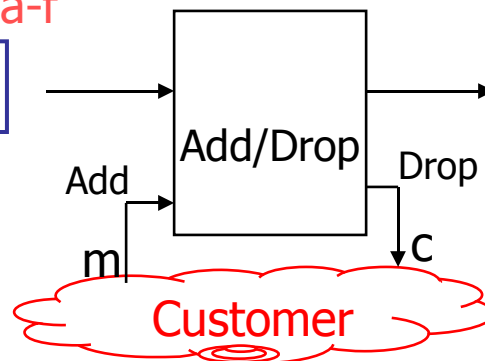

Lower speed streams a-f



High speed stream

## 2.2 Advantages of SDH over PDH

---

### 2. **Management** $\Rightarrow$ PDH lacks essential network management features

- SDH/SONET standards has extensive management information
  - Monitoring performance of signal streams
  - Identification of traffic types and connectivity
  - Fault identification and reporting
  - Data communication channel for exchange of management info between nodes
- In PDH done by modulating low frequency supervisory signals on top of the multiplexed stream
  - This supervisory signal has to be removed, accessed and re-applied when going through a mux-mountain

## 2.2 Advantages of SDH over PDH

---

3. **Interoperability**  $\Rightarrow$  Only multiplexing hierarchy standardized for PDH
- Lack of **standard signal format** on transmission link
  - **Proprietary** (vendor specific) line coding, optical interfaces etc. in terminal equipment
  - Difficult to **interconnect equipment** from **different vendors**
  - SDH/SONET define standard optical interfaces to enable **interoperability**
    - Some aspects (e.g. Datacom management channel) were standardized later, so interoperability is not straightforward in some cases

## 2.2 Advantages of SDH over PDH

---

### 4. Network Availability

- SDH/SONET standards define network topologies and protection switching for high availability service
  - sub 60 ms service restoration time after failure in SDH/SONET networks
- Restoration in PDH networks takes several seconds to minutes

# 3. SDH Multiplexing and Framing

---

- ❑ PDH multiplexer interleaves bits from individual lower-speed streams into higher-speed aggregate stream
  
- ❑ SDH/SONET employs a much more sophisticated multiplexing stream
  - Use **pointers** to indicate location of multiplexed **payload data** within a frame
  - Pointer processing easily implemented with current VLSI circuits
  
- ❑ Basic transmission rates
  - SHD  $\Rightarrow$  155 Mb/s STM-1 (**synchronous transport module-1**)
  - SONET  $\Rightarrow$  51.48 Mb/s (STS-1)

# 3. SDH Multiplexing and Framing

- Currently defined rates for SDH and SONET shown below

Table 6.2 Transmission rates for SONET/SDH, adapted from [SS96].

SONET Signal	SDH Signal	Bit Rate (Mb/s)
STS-1		51.84
STS-3	STM-1	155.52
STS-12	STM-4	622.08
STS-24		1244.16
STS-48	STM-16	2488.32
STS-192	STM-64	9953.28
STS-768	STM-256	39,814.32

- STS-N signal is an electrical signal confined to SONET equipment
- Optical carrier-N (OC-N) is corresponding optical signal e.g. STS-3 ⇒ OC-3
- STM-N interfaces already defined for optical transmission

# 3. SDH Multiplexing and Framing

- ❑ In SDH, payload packaged in a **container** (C-x)
  - 2D array of bytes with specified number of rows and columns
  - STM-1 ⇒ container-4 or C-4
  - C-4 designed to accomodate E4 (139.264 Mb/s) PDH stream
  - C-11, C-12, C-2 and C-3 are smaller containers for lower order PDH streams
    - C-11 ⇒ DS1 (1.544 Mb/s)
    - C-12 ⇒ E1 (2.048 Mb/s)
    - C-2 ⇒ DS2 (6.312 Mb/s)
    - C-3 ⇒ E3 (34.368 Mb/s) and DS3 (44.736 Mb/s)

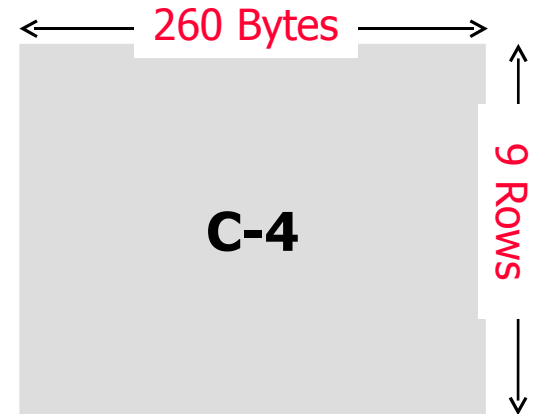

Figure: C-4 construction

# 3. SDH Multiplexing and Framing

- ❑ Container + path overhead (POH) bytes = virtual container (VC-x)
  - “Virtual” because POH may be placed at different points within payload
  - C-4 + POH ⇒ VC-4

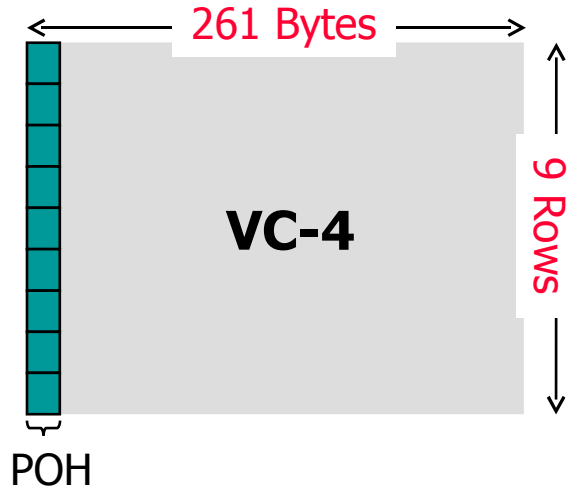

Figure: VC-4 construction

J1	J1 VC-n Path Trace
B3	B3 Path BIP-8
C2	C2 Path Signal Label
G1	G1 Path Status
F2	F2 Path User Channel
H4	H4 TU Multiframe Indicator
F3	F3 Path User Channel
K3	K3 Automatic Protection Switching
N1	N1 Network Operator (TCM)

*Path Overhead*

SDH	Digital Bit Rate	Size of VC
VC-11	1.728 Mbit/s	9 rows, 3 columns
VC-12	2.304 Mbit/s	9 rows, 4 columns
VC-2	6.912 Mbit/s	9 rows, 12 columns
VC-3	48.960 Mbit/s	9 rows, 85 columns
VC-4	150.336 Mbit/s	9 rows, 261 columns

# 3. SDH Multiplexing and Framing

---

- VCs classified on two levels
  - Low-order VCs  $\Rightarrow$  VC-11, VC-12, VC-2
  - High-order VCs  $\Rightarrow$  VC-3, VC-4
- Low-order VCs can be multiplexed to share a high-order VC
  - Each aligned with a **tributary unit** (TU) pointer to form TU-11, TU-12 etc.
  - TUs multiplexed to form **tributary unit groups** (TUG-2 or TUG-3)
  - Example:  $3 \times \text{VC-12s} \Rightarrow 3 \times \text{TU-12} \Rightarrow 1 \times \text{TUG-2}$  and then  $7 \times \text{TUG-2} \Rightarrow \text{VC-3}$

# 3. SDH Multiplexing and Framing

- A VC becomes **administrative unit (AU)** when **AU pointer** bytes are added
  - AU pointers specify where in the AU the VC begins
  - Multiple AUs can be multiplexed into **AU groups (AUG-1,-4,-16,-64,-256)**

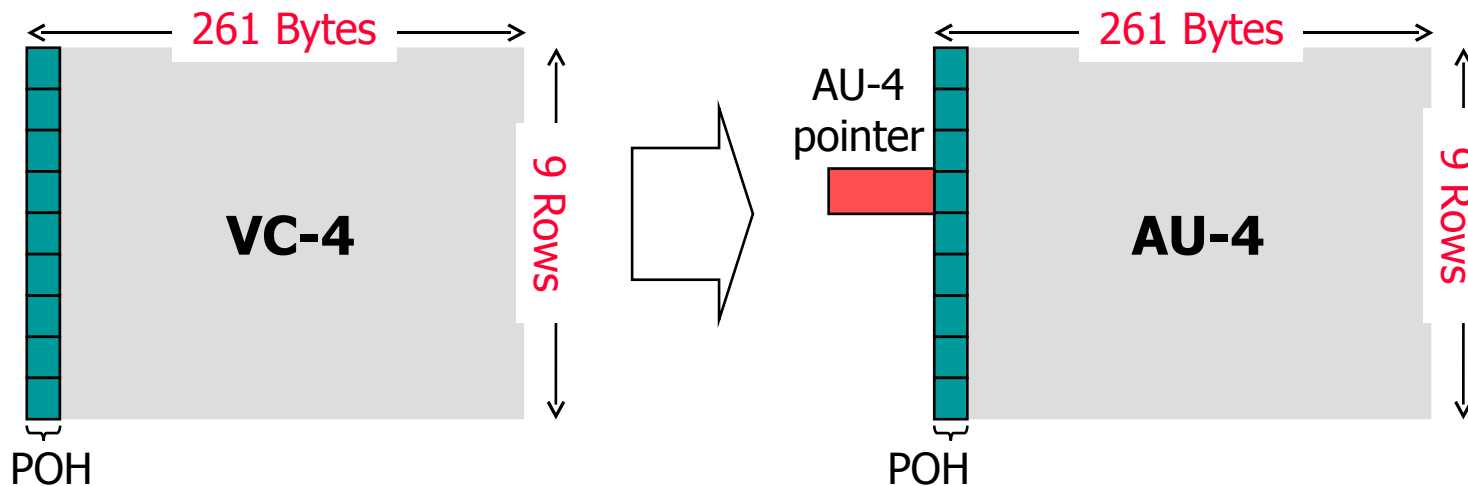

Example VC-4 and AU-4 constructions for basic STM-1 frame

# 3. SDH Multiplexing and Framing

- ❑ Hierarchical multiplexing structure employed in SDH/SONET
- ❑ Pointers allow VCs to be carried in SDH payload as independent data packages

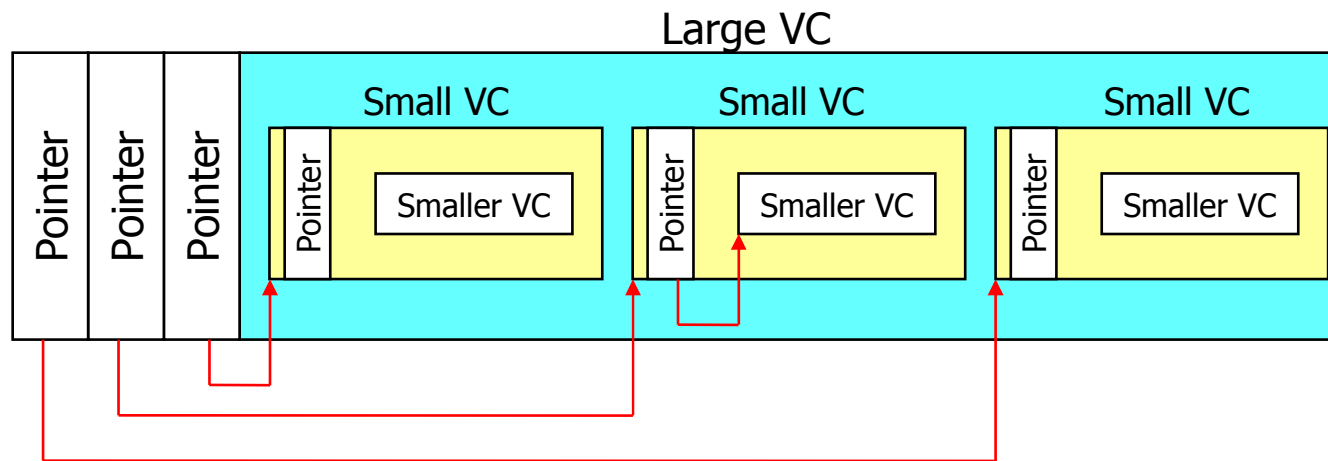

# 3. SDH Multiplexing and Framing

- ❑ AUG-N are multiplexed with **section overhead (SOH)** to form STM-N frames e.g. AUG-16  $\Rightarrow$  STM-16
  - SOH consists of **regenerator SOH (RSOH)** and **multiplex SOH (MSOH)**
  - STM-Nc has single set of overhead bytes and a concatenated or **locked payload**

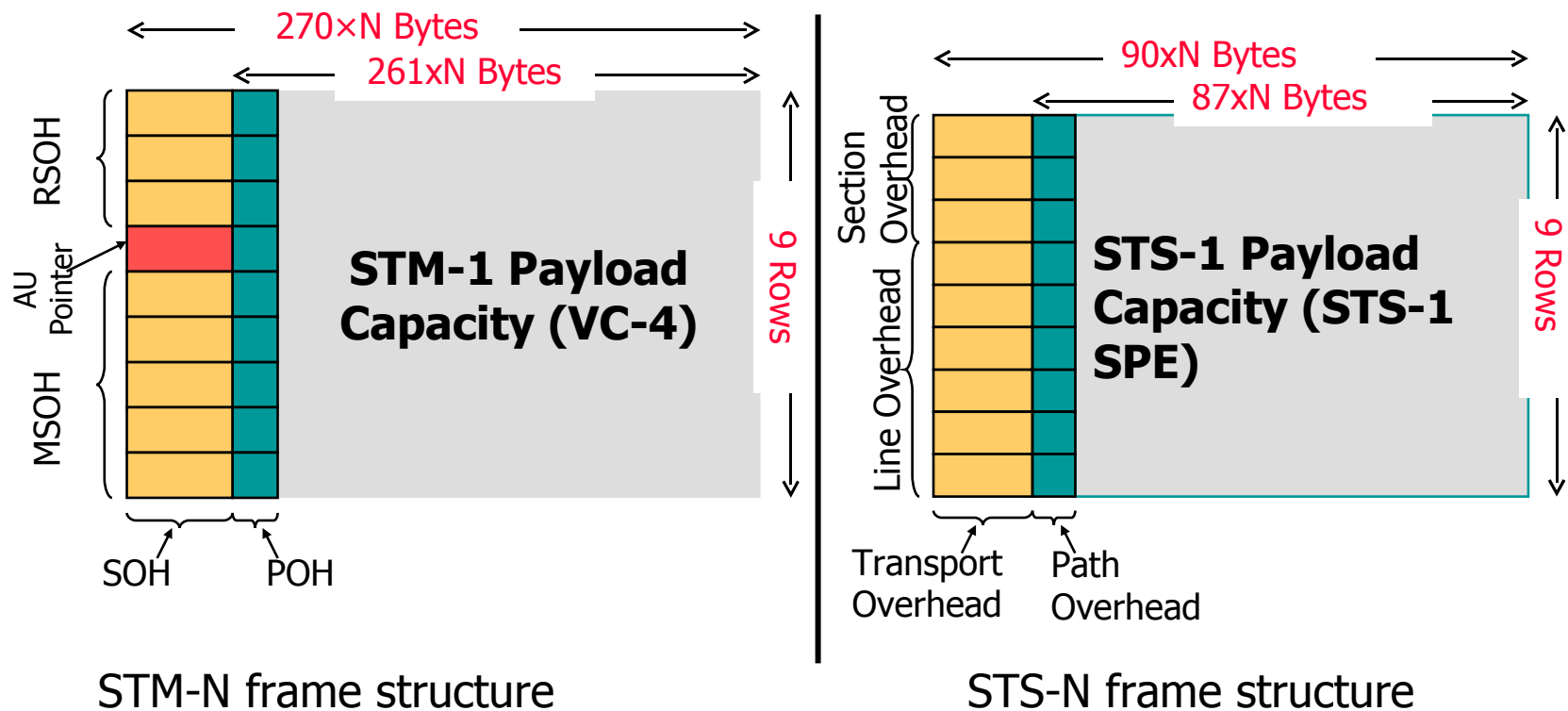

# 3. SDH Multiplexing and Framing

- ❑ An STM-N frame has a fixed **125 μs** duration
  - Frame rate is 8000 frames/s
  - Derived 8 KHz sampling rate for analog voice
  - Transmission order of bytes is row by row

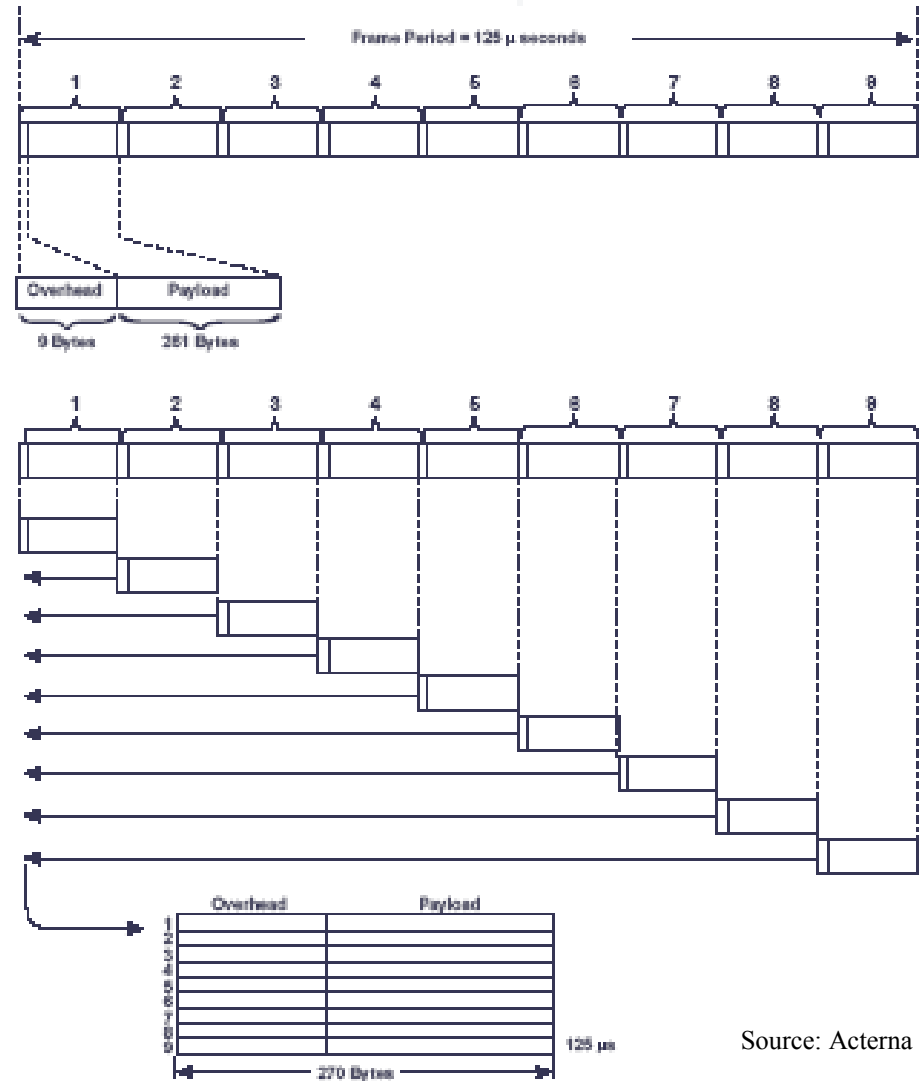

Source: Acterna

# 3. SDH Multiplexing and Framing

□ To evaluate SDH line rates

$$\text{STM-N bit rate} = \text{STM-N frame capacity} \times \text{frame rate}$$

where frame rate = 8000 frames/s

and STM-N frame capacity =  $N \times 270 \text{ bytes/row} \times 9 \text{ rows/frame} \times 8 \text{ bits/byte}$

- Example: N=1 for STM-1 and therefore bit rate is 155.52Mb/s

Frame Format	Bit Rate
STM-1	155.52 Mbit/s
STM-4	622.08 Mbit/s
STM-16	2.488 Gbit/s

# 3. SDH Multiplexing and Framing

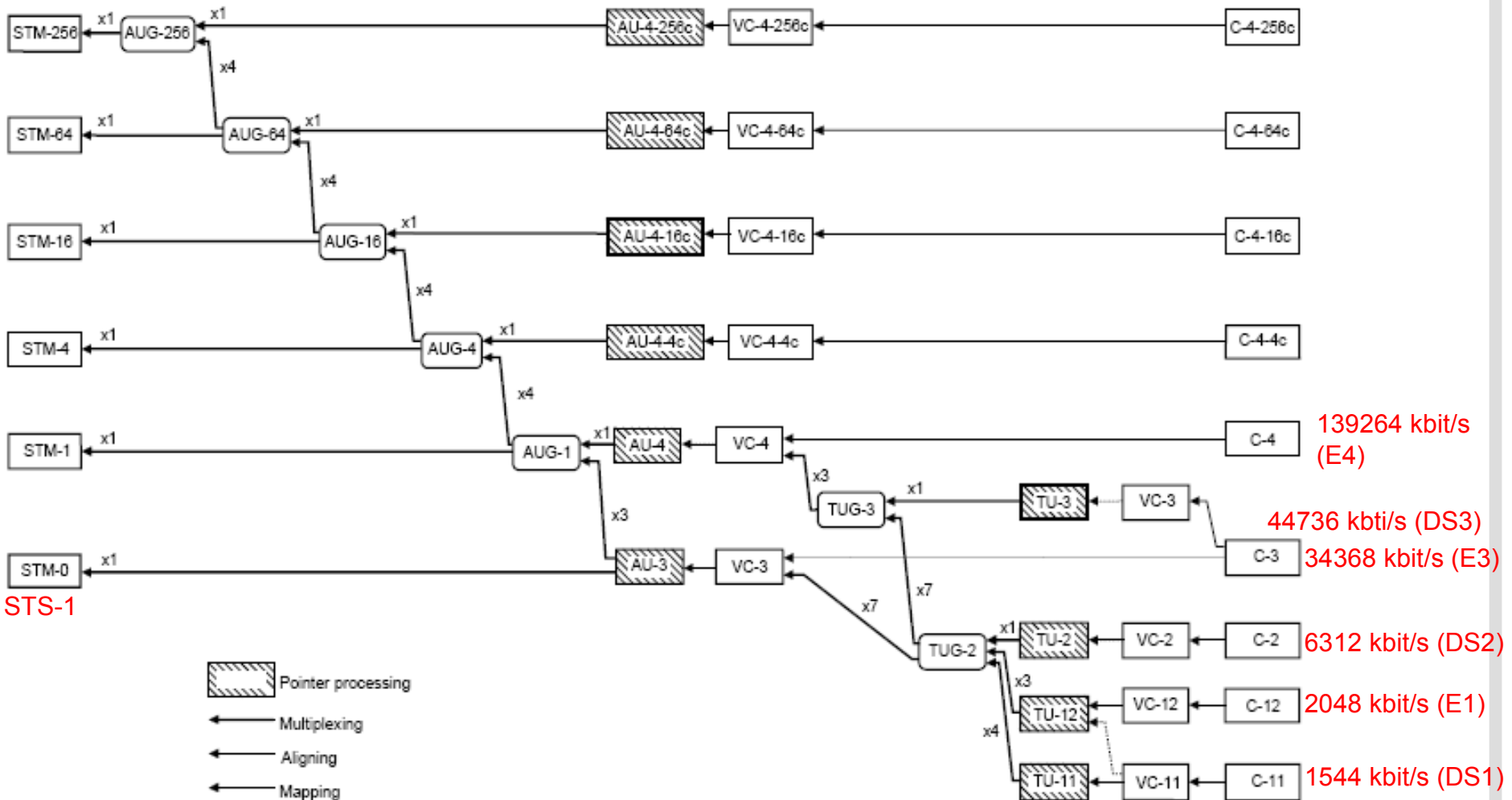

Example of multiplexing hierarchies for transporting PDH and SDH streams

## 4. SDH Layers

---

- Networks are very complicated entities
  - Variety of different functions performed by different components (network elements)
  - Components from different vendors interoperating together

# 4. SDH Layers

- ❑ Network view simplified by breaking functions into different layers
  - Each layer performs a certain set of functions
    - Provide services to the next higher layer
    - Expects some services from layers beneath it

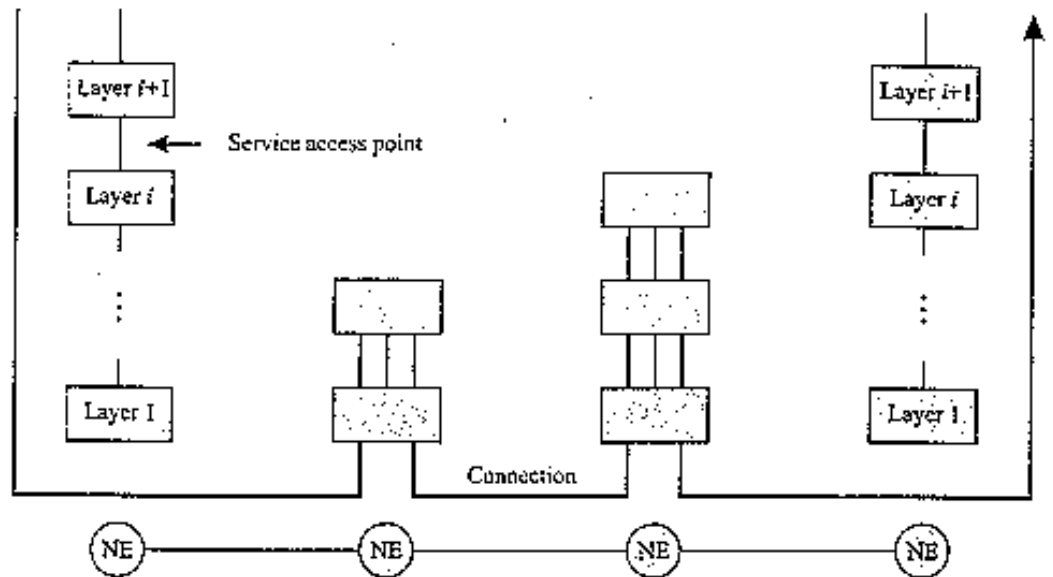

NE: network elements

Figure 6.5 Layered hierarchy of a network.

# 4. SDH Layers

- SDH was developed using the client/server layer approach

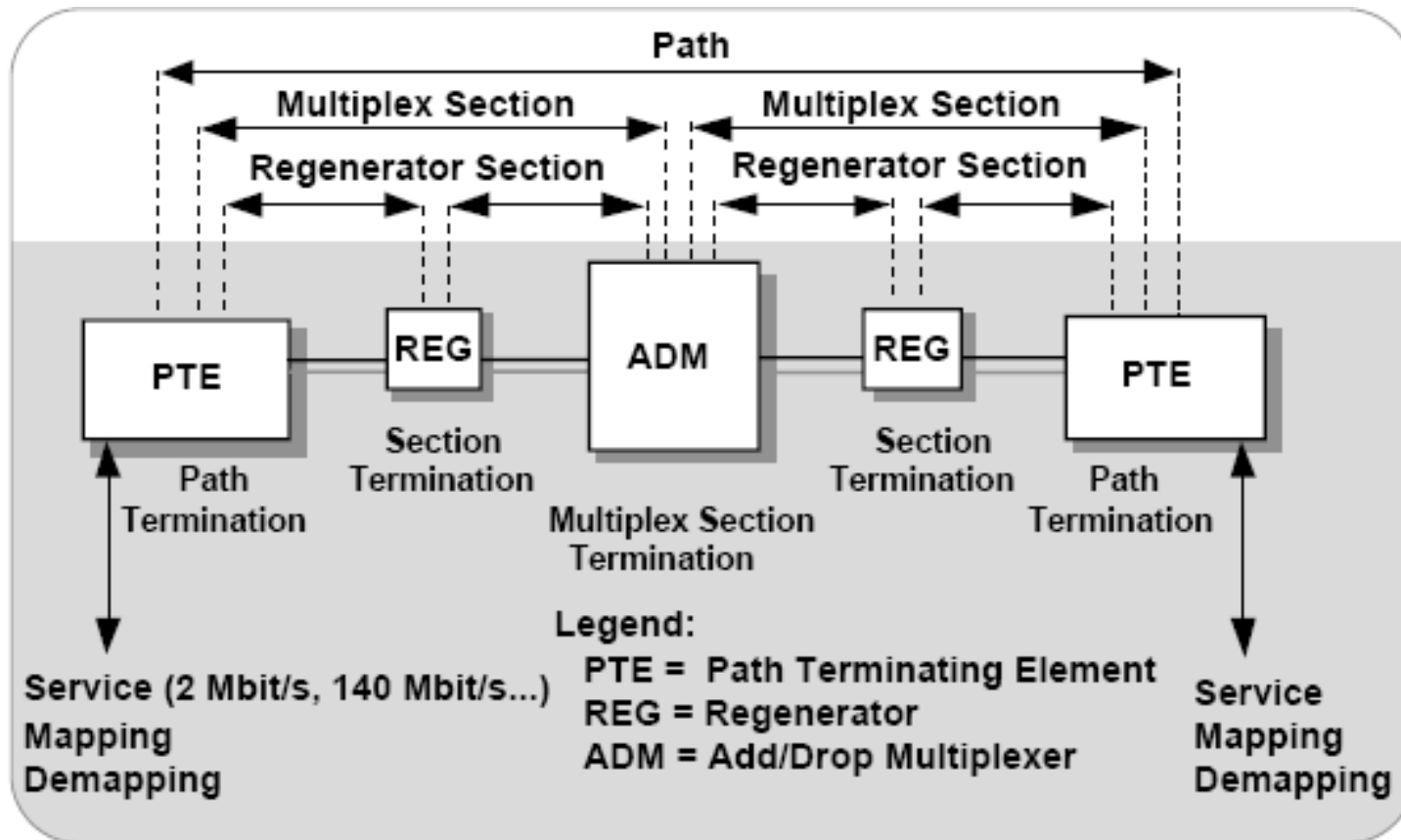

Source: "SDH Standard Primer," Tektronix Application Note

# 4.1 SDH Layer Functions

---

- SDH layer has four sublayers
  - **Physical layer** ⇒ responsible for actual transmission of bits across the fiber.
    - Define characteristics of fibers, transmitters, receivers and encoding.
  - **Path layer** ⇒ responsible for **end-to-end connection** between nodes.
    - Mapping PDH, ATM etc. into SDH payload.
  - **Multiplexer section (MS) layer** ⇒ multiplexes path-layer connections on single link
    - Frame synchronization
    - Protection switching
  - **Regenerator section (RS) layer** ⇒ responsible for segments between regenerators
    - Framing, scrambling etc.

# 4.1 SDH Layer Functions

Example figure showing termination of different SDH sublayers

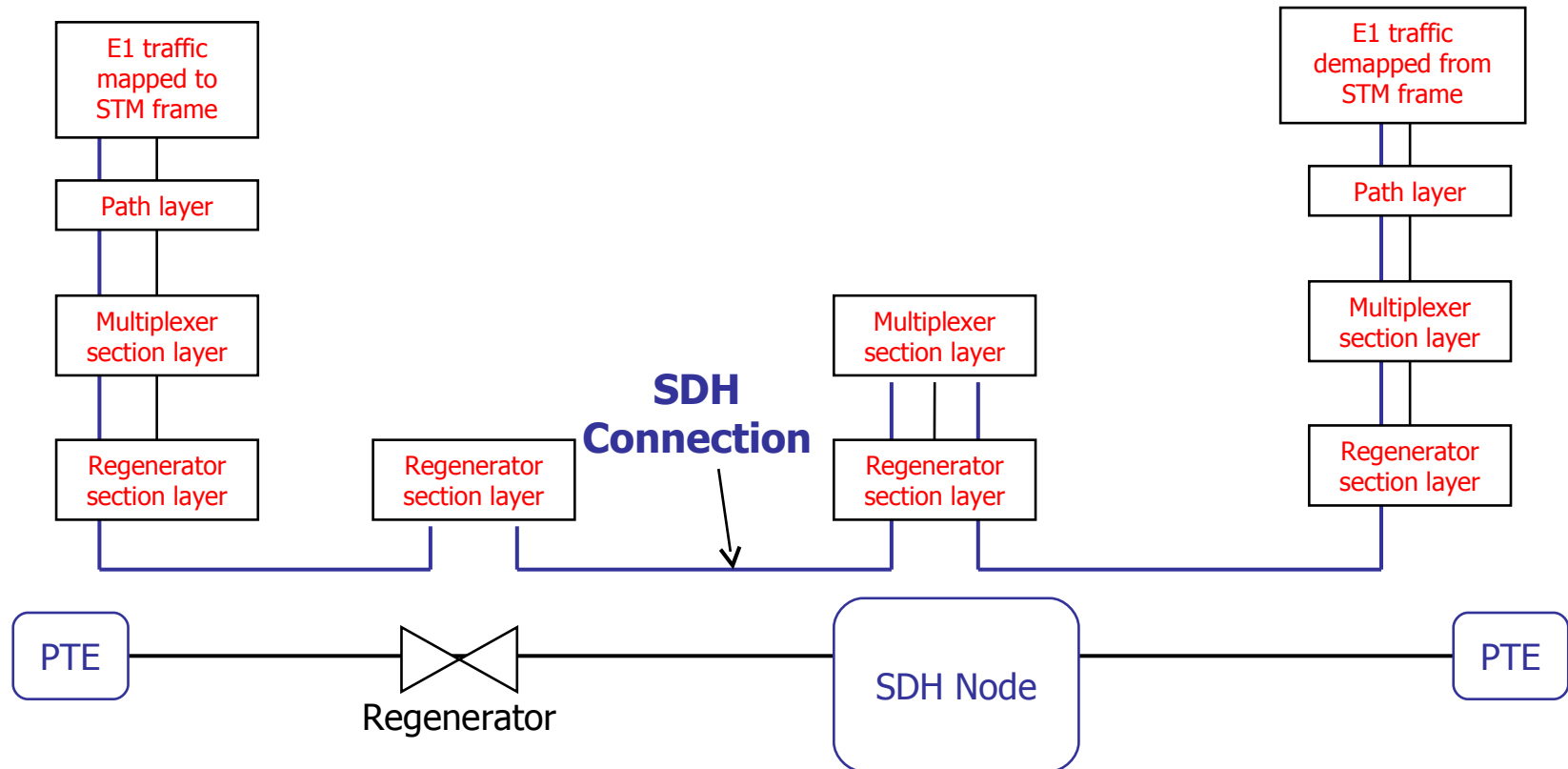

PTE: Path terminating equipment

# 4.1 SDH Layer Functions

- ❑ Each layer (except physical layer) has **associated overhead bytes**
  - POH for path layer, MSOH for multiplexer section layer and RSOH for regenerator section layer

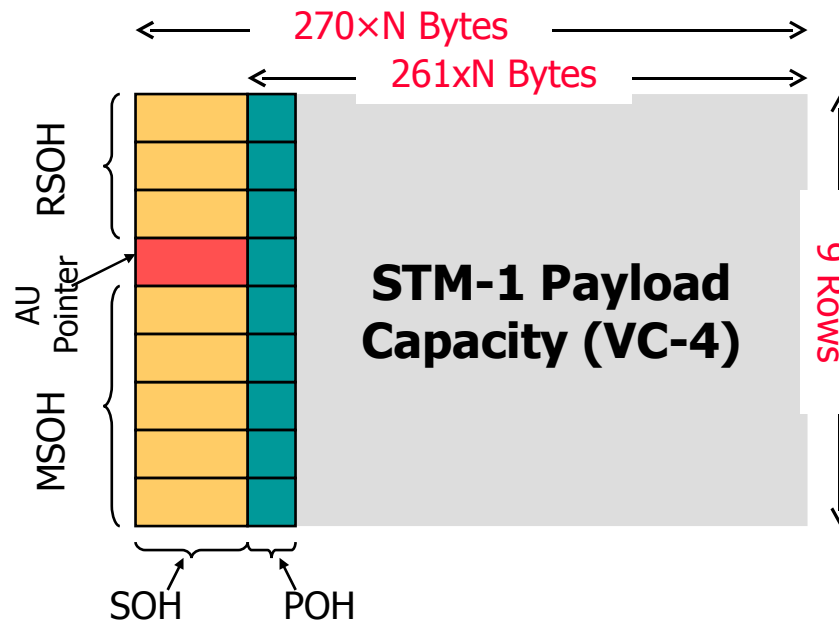

STM-N frame structure

# 4.1 SDH Layer Functions

- **AU pointer bytes** indicate the matrix address of first byte of VC payload in each STM-N frame:

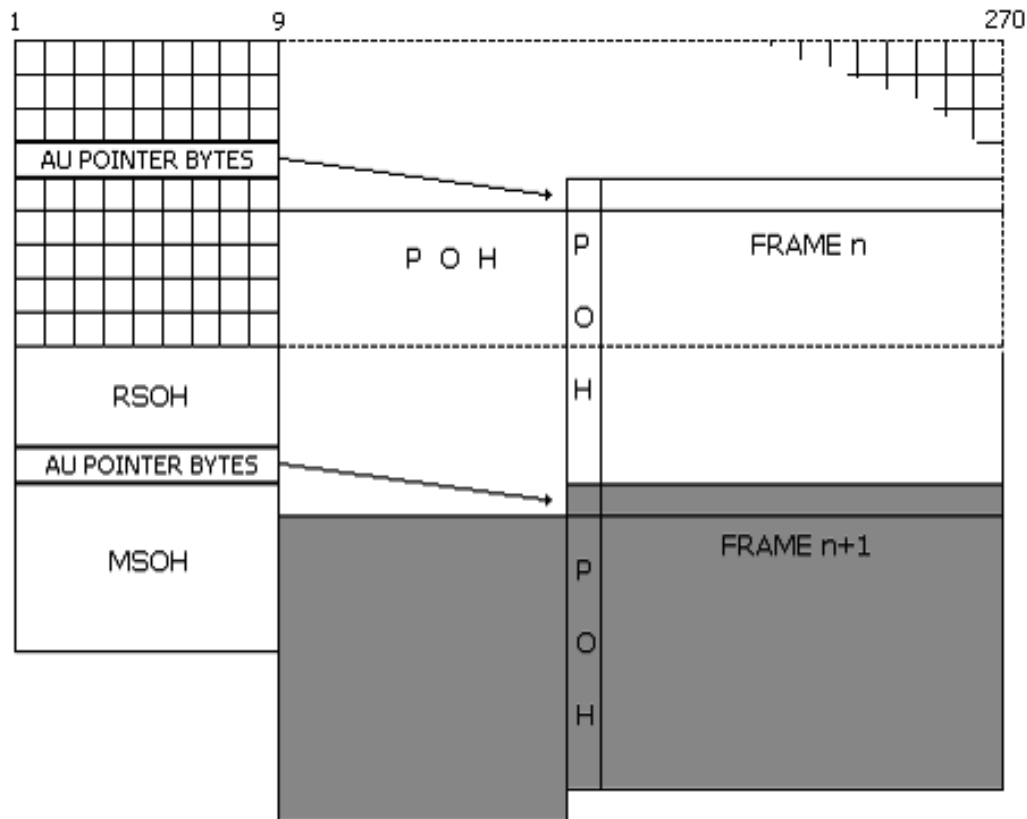

Source: Tacheon "An Introduction to the SDH Protocol," zZine Magazine, Oct 2006

# 4.1 SDH Layer Functions

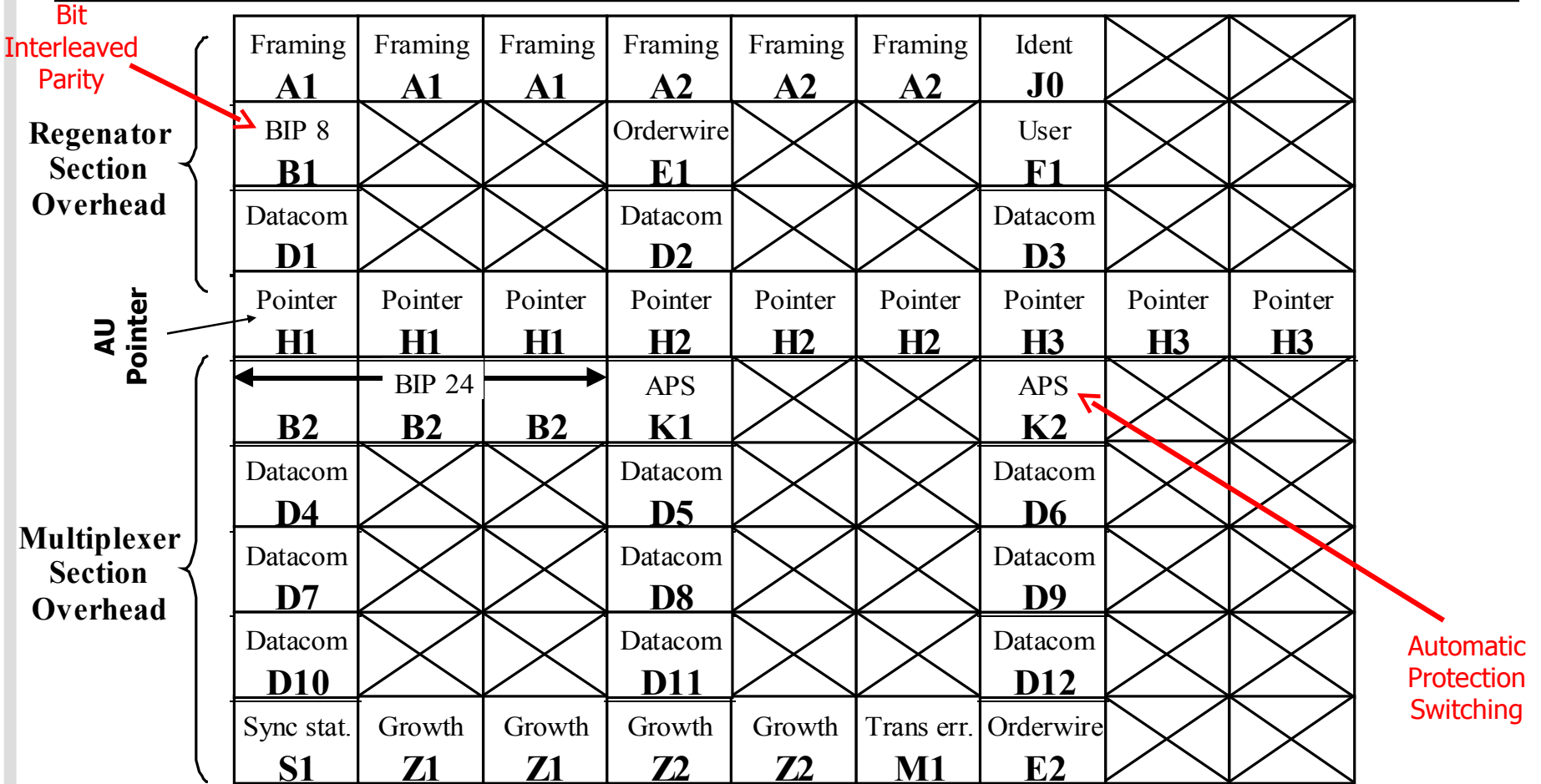

**Figure:** SDH section overhead bytes. Crossed bytes are auxiliary bytes

# 4.1 SDH Layer Functions

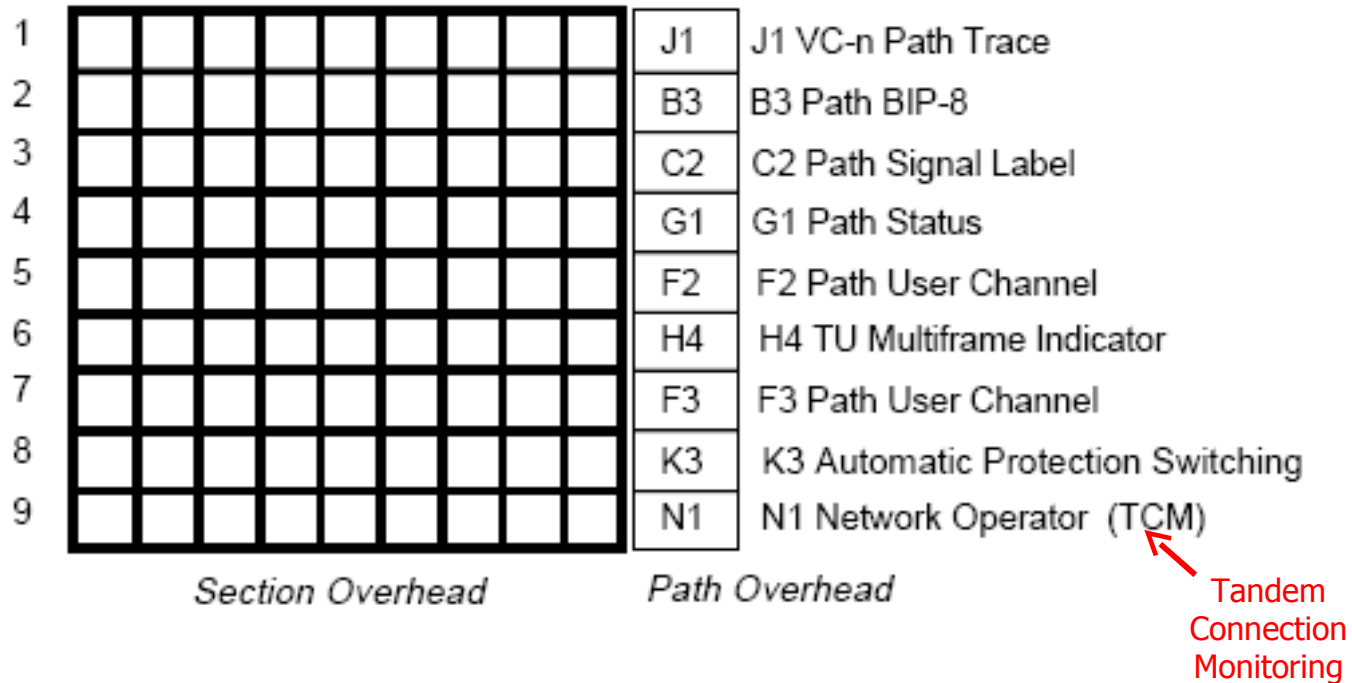

**Figure:** SDH path overhead bytes.

Source: "SDH Standard Primer," Tektronix Application Note

## 4.2 Example Layer SDH Function

---

- Assigned overhead bytes fulfill various functions, for example:
  - **Framing bytes** (A1=11110110, A2=00101000) indicate where frame begins and ends
  - **RS Data Communications Channel bytes** (D1-D3) forming a 192 kbit/s message channel for control, maintenance, remote provisioning, monitoring, administration and other communication needs
    - **MS Data communications channel bytes** (D4-D12) form a 576 kbit/s message channel for same uses as above
  - **Automatic protection switching bytes** (K1-K3) for signaling to enable recovery from network failure
  - **RS/MS Orderwire bytes** (E1, E2) each form 64 kbit/s voice channel links for use by craftspersons
  - **Bit interleaved parity** (BIP) bytes for in-service error monitoring

## 4.2 Example Layer SDH Function

---

- For BIP-X calculation and monitoring
  - **Monitored block** divided into **X-bit words** and bits in each column are summed
  - Resulting X-bit long **BIP-X code** has 1 and 0 bits for columns with odd and even bit sums respectively
  - BIP-X code is **transmitted as overhead** with monitored block
  - **Receiver recalculates BIP-X code** for received block and compares with received code to check for **block errors**

# 4.2 Example Layer SDH Function

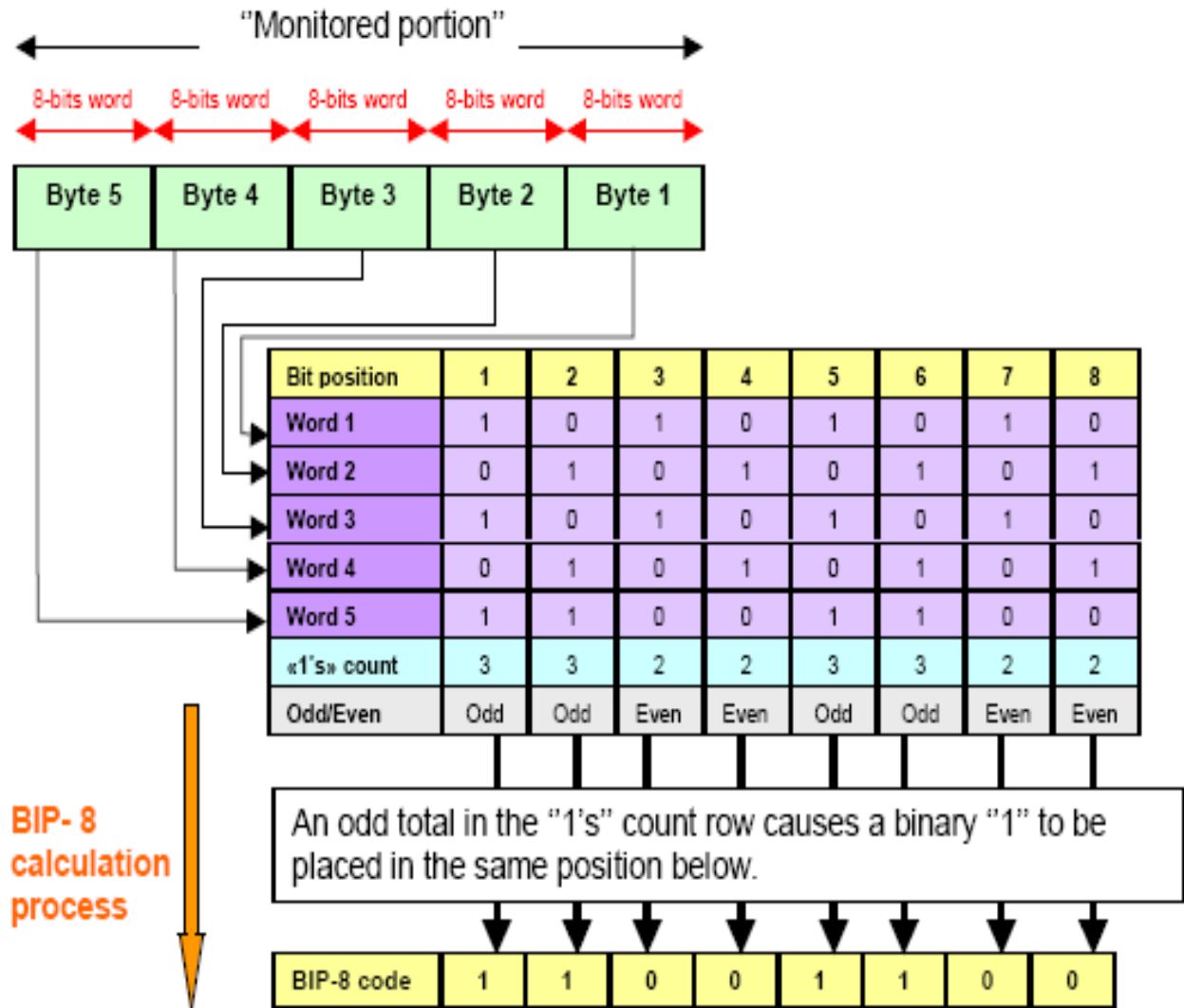

**Figure (a):** Example BIP-8 calculation for block with five 8-bit words

# 4.2 Example Layer SDH Function

- BIP-X code of current SDH frame placed in following frame

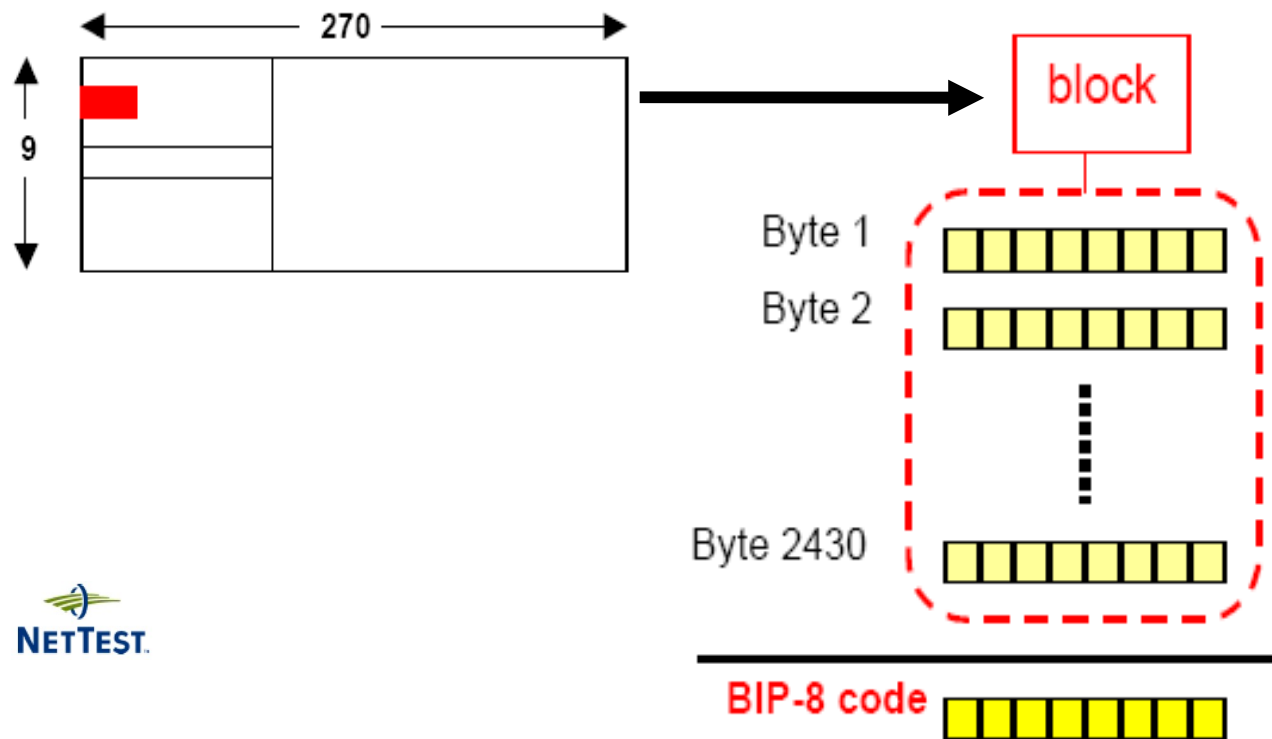

**Figure (a):** Calculation of BIP-8 code of an STM-1 frame for regenerator section error monitoring. Result inserted in **B1** byte of following frame.

# 4.2 Example Layer SDH Function

- ❑ Different BIP calculations performed in SDH networks to monitor errors in:
  - Regenerator sections (BIP-24)
  - Multiplex sections (BIP-8)
  - End-to-end paths (BIP-8)

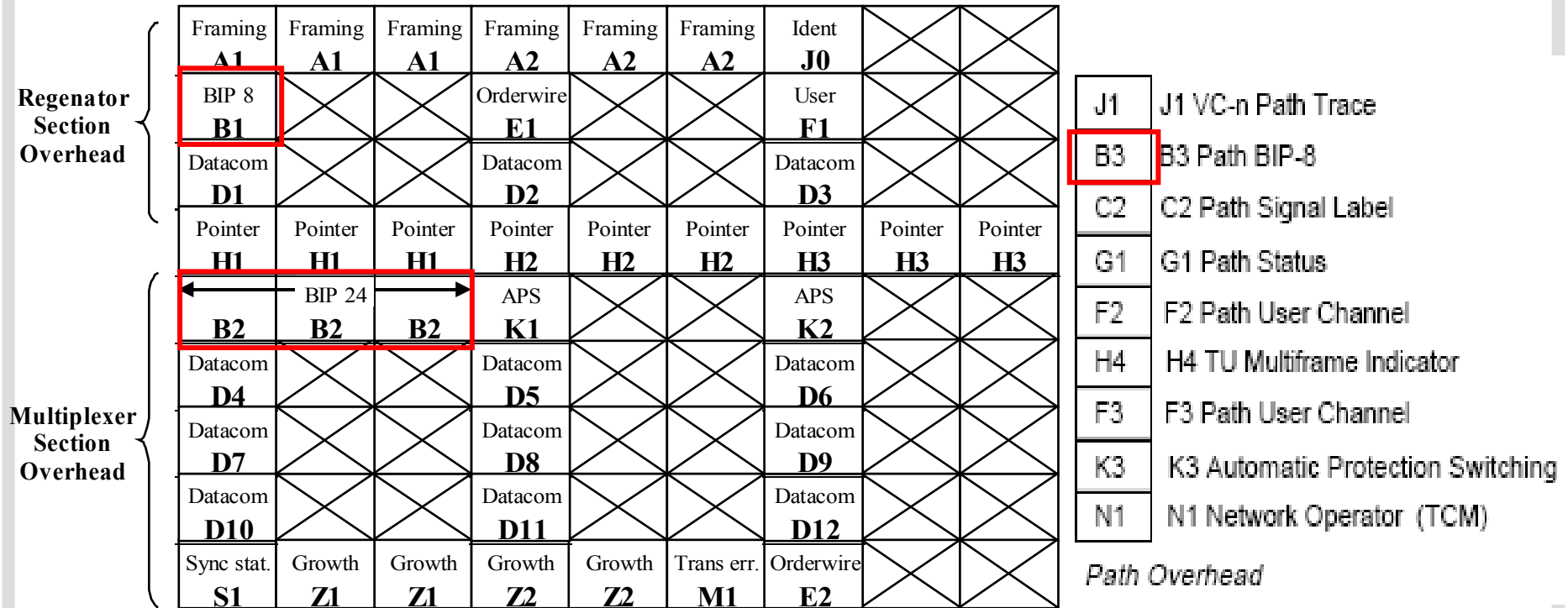

# 4.3 SDH Physical Layer

- Physical layer interfaces defined for SDH/SONET
  - Depends on **bit rate** and target **distance** (link loss)

Connection	Code	Reach (km)	Wavelength (nm)
Intraoffice	I-	<2	1310
Short haul interoffice	S-	15	1310
		40	1550
Long-haul interoffice	L-	40	1310
		80	1550
Very-long-haul interoffice	V-	60	1310
		120	1550
Ultra-long-haul interoffice	U-	160	1550

# 4.3 SDH Physical Layer

- Different physical layer interfaces defined for SDH (ITU-T G.957, G.691)

- Single-mode fiber (ITU-T G.652).
- Dispersion-shifted fiber (ITU-T G.653).
- MLM: multi-longitudinal mode lasers.
- SLM: single-longitudinal mode lasers.

Bit Rate	Code	Wavelength (nm)	Fiber	Loss (dB)	Transmitter	Dispersion (ps/nm)
STM-1	I-1	1310	G.652	0-7	LED/MLM	18/25
	S-1.1	1310	G.652	0-12	MLM	96
	S-1.2	1550	G.652	0-12	MLM/SLM	296/NA
	L-1.1	1310	G.652	10-28	MLM/SLM	246/NA
	L-1.2	1550	G.652	10-28	SLM	NA
	L-1.3	1550	G.653	10-28	MLM/SLM	296/NA
STM-4	I-4	1310	G.652	0-7	LED/MLM	14/13
	S-4.1	1310	G.652	0-12	MLM	74
	S-4.2	1310	G.652	0-12	SLM	NA
	L-4.1	1310	G.652	10-24	MLM/SLM	109/NA
	L-4.2	1550	G.652	10-24	SLM	ffs
	L-4.3	1550	G.653	10-24	SLM	NA
	V-4.1	1310	G.652	22-33	SLM	200
	V-4.2	1550	G.652	22-33	SLM	2400
	V-4.3	1550	G.653	22-33	SLM	400
	U-4.2	1550	G.652	33-44	SLM	3200
U-4.3	1550	G.653	33-44	SLM	530	
STM-16	I-16	1310	G.652	0-7	MLM	12
	S-16.1	1310	G.652	0-12	SLM	NA
	S-16.2	1550	G.652	0-12	SLM	ffs
	L-16.1	1310	G.652	10-24	SLM	NA
	L-16.2	1550	G.652	10-24	SLM	1600
	L-16.3	1550	G.653	10-24	SLM	ffs
	V-16.2	1550	G.652	22-33	SLM	2400
	V-16.3	1550	G.653	22-33	SLM	400
	U-4.2	1550	G.652	33-44	SLM	3200
	U-4.3	1550	G.653	33-44	SLM	530

# 4.3 SDH Physical Layer

- ❑ Other PHY parameters not shown in the table of previous slide
  - Maximum allowable DGD (PMD limit)
  - Minimum required optical return loss (ORL)
  - Maximum optical path power penalty
  - etc.

Parameters specified for STM-16 optical interfaces

Application code (Table 1)	Unit	V-16.2 (1, 2)	V-16.3 (1, 2)	U-16.2 (1, 2)	U-16.3 (1, 2)
<b>Transmitter at reference point MPI-S</b>					
Operating wavelength range	Nm	1 530- 1 565	1 530- 1 565	1 530- 1 565	1 530- 1 565
Mean launched power					
– maximum	dBm	13	13	15	15
– minimum	dBm	10	10	12	12
Spectral characteristics					
– maximum –20 dB width	Nm	ffs	ffs	Ffs	ffs
– chirp parameter, $\alpha$	Rad	ffs	ffs	Ffs	ffs
– maximum spectral power density	mW/MHz	ffs	ffs	Ffs	ffs
– minimum SMSR	DB	ffs	ffs	Ffs	ffs
Minimum EX	DB	8.2	8.2	10	10
<b>Main optical path, MPI-S to MPI-R</b>					
Attenuation range					
– maximum	DB	33	33	44	44
– minimum	DB	22	22	33	33
Chromatic dispersion					
– maximum	ps/nm	2 400	400	3 200	530
– minimum	ps/nm	NA	NA	NA	NA
Maximum DGD	Ps	120	120	120	120
Min ORL of cable plant at MPI-S, including any connectors	DB	24	24	24	24
Maximum discrete reflectance between MPI-S and MPI-R	DB	-27	-27	-27	-27
<b>Receiver at reference point MPI-R</b>					
Minimum sensitivity (BER of $1 \cdot 10^{-15}$ )	dBm	-25	-24	-34	-33
Minimum overload	dBm	-9	-9	-18	-18
Maximum optical path penalty	dB	2	1	2	1
Maximum reflectance of receiver, measured at MPI-R	dB	-27	-27	-27	-27

NOTE 1 - The optical preamplifier specified for e.g. U-16.x or V-64.x systems may be used instead of an optical booster amplifier. That system may get a somewhat lower attenuation range.  
 NOTE 2 - Under the assumptions given in subclause 8.4, a G.957 transmitter and receiver together with a booster amplifier gives similar system performance.

# 5. Elements of SDH Infrastructure

## Terminal multiplexer (TM)

- Path terminating equipment (PTE) that can concentrate or aggregate PDH or STM-N signals

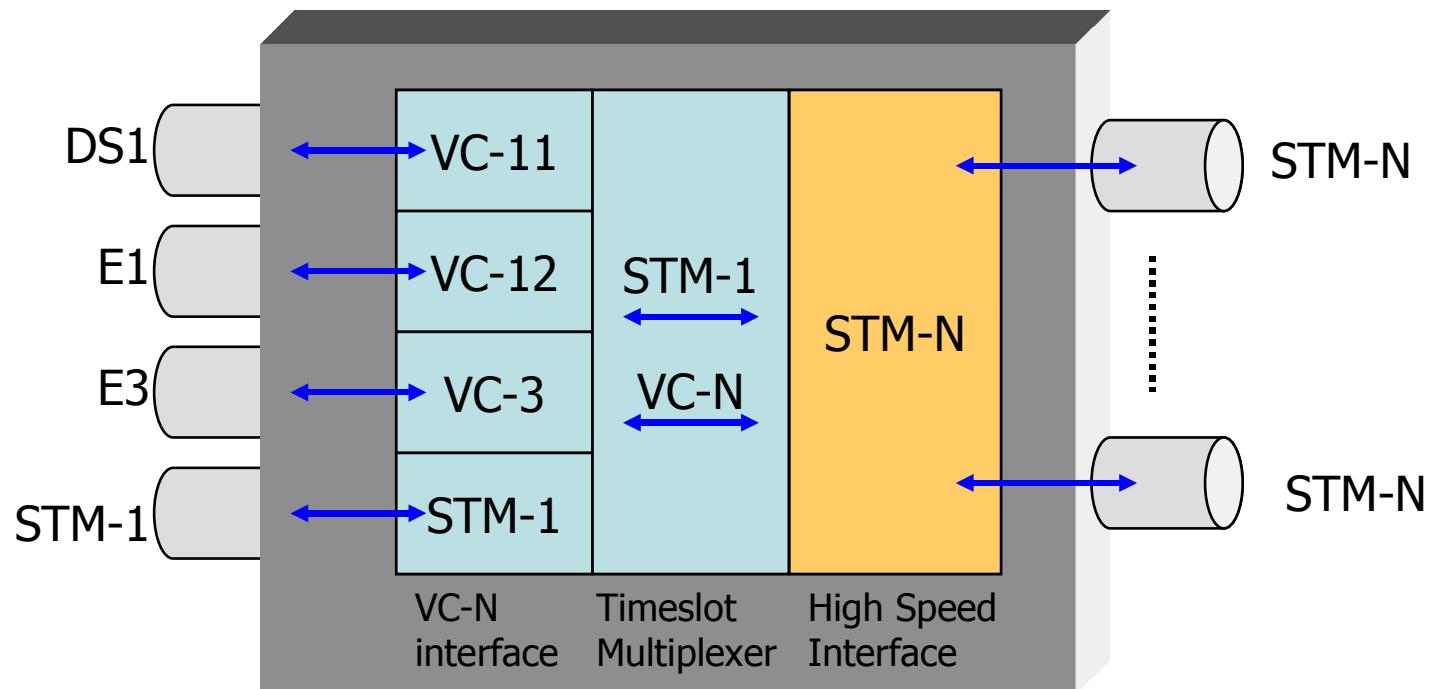

# 5. Elements of SDH Infrastructure

## ❑ Add-Drop Multiplexer (ADM)

- PTE that can multiplex/demultiplex various signal to form and STM-N
- At an add/drop site only those signals that need be accessed are dropped or inserted

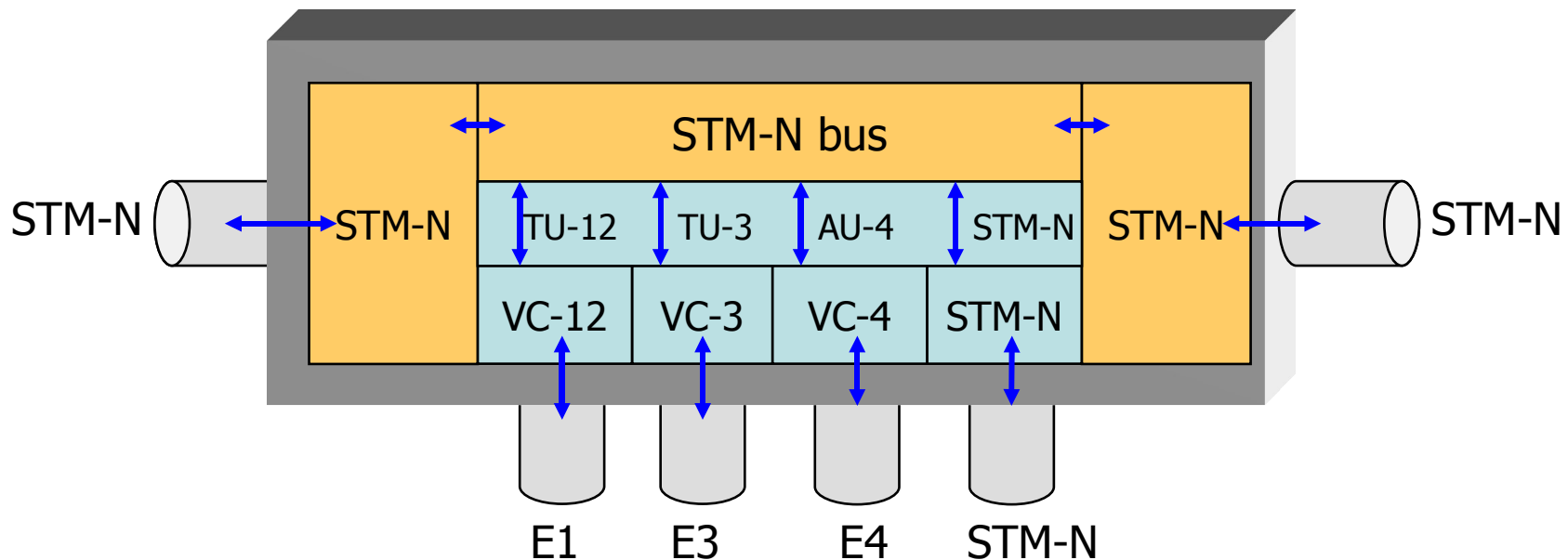

# 5. Elements of SDH Infrastructure

## ❑ Digital cross-connect (DCS)

- Switching streams from input to required output ports
  - Automated software control  $\Rightarrow$  previously done manually via patch panel!
  - Reduced labour costs and human errors
- Add/drop, Multiplexing/Demultiplexing

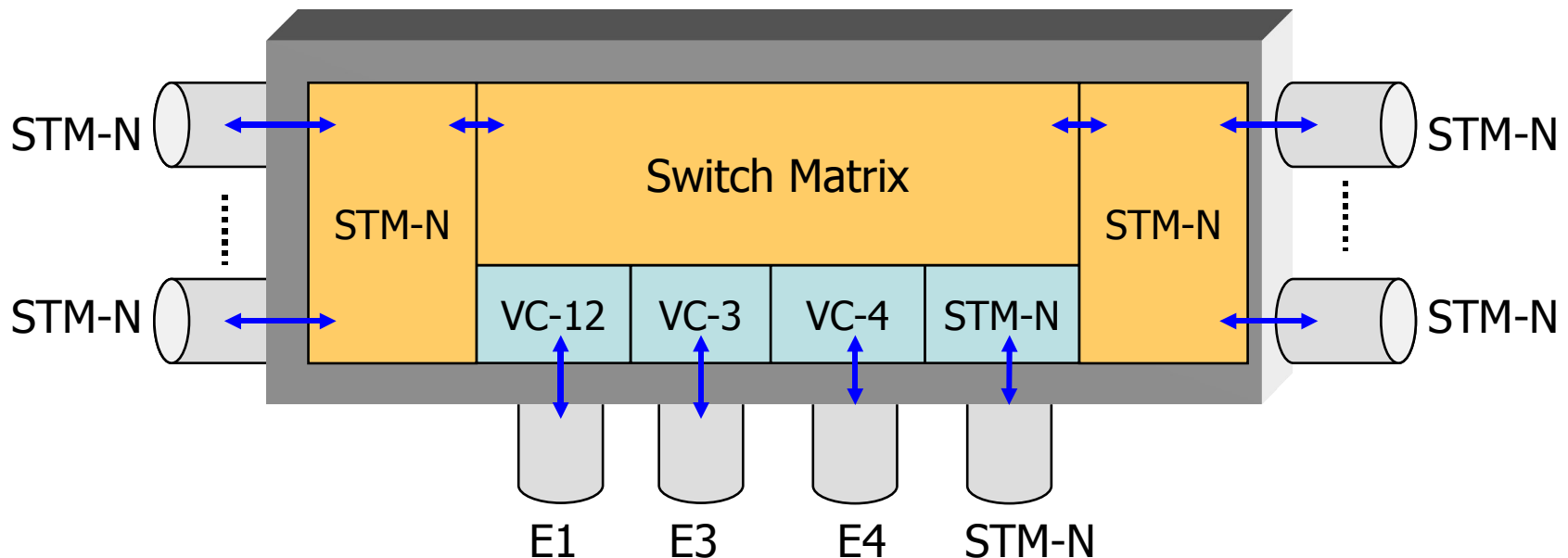

# 6. SDH Network Configuration

- ❑ Deployed SDH/SONET networks is a mixture of various configurations
  - Rings, linear add/drop, mesh and point-to-point link configurations

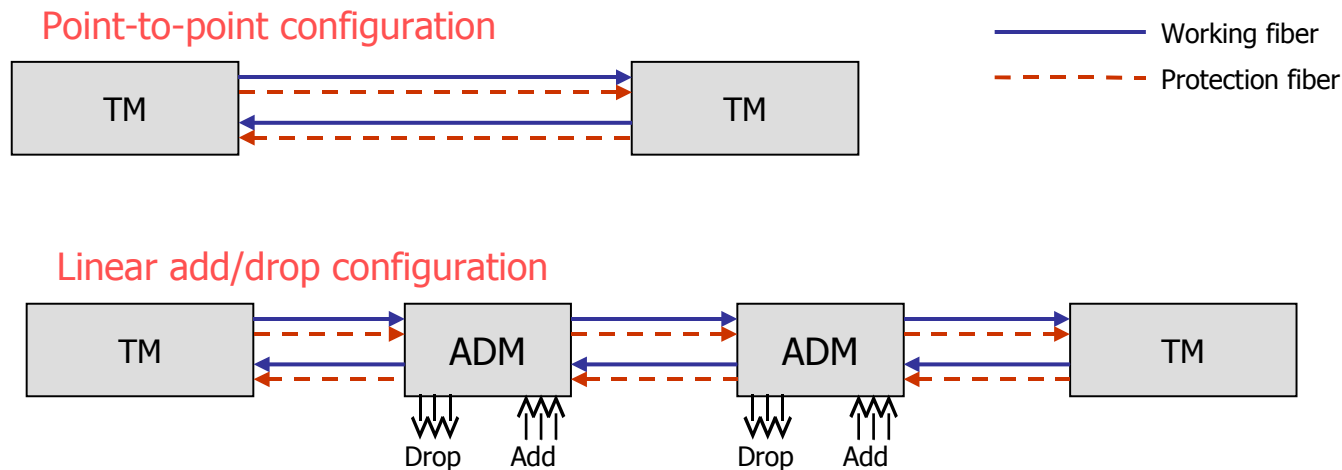

# 6. SDH Network Configuration

- ❑ Ring topologies popular due to resilience to network failures
- ❑ **Subnetwork connection protection (SNCP) rings**
  - Access ring, metropolitan edge, LANs
  - Consists of dual-fiber counter-rotating ring (1 working and 1 protection fiber)
  - Duplicate traffic sent in both directions

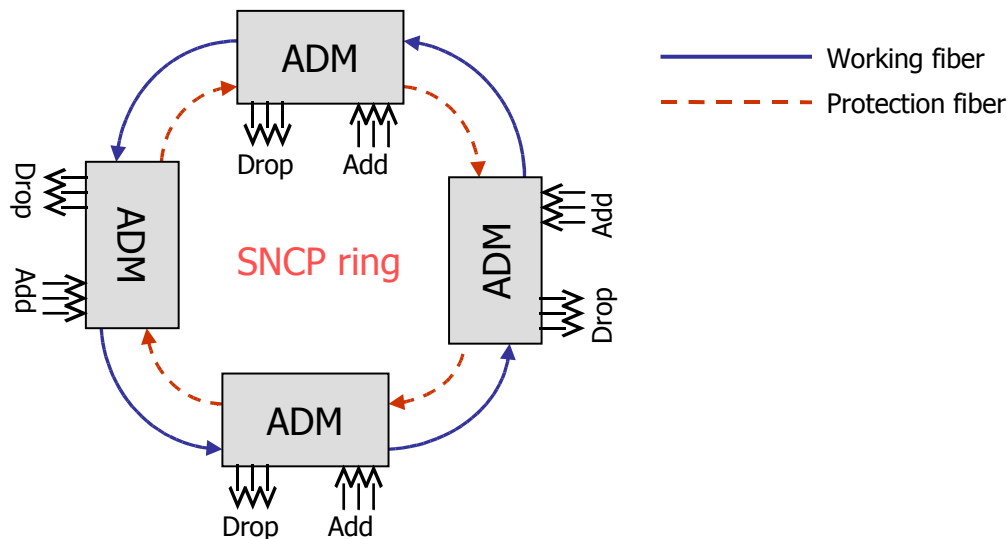

# 6. SDH Network Configuration

- ❑ **Multiplex section-shared protection ring (MS-SPRing)**
  - ❑ Metropolitan core ring, medium or large LANs,
  - ❑ Using 2 fibers (MS-SPRing/2)  $\Rightarrow$  50% capacity reserved for working and 50% for protection on all fibers
  - ❑ Using 4 fibers (MS-SPRing/4)  $\Rightarrow$  2 working fibers and 2 protection fibers

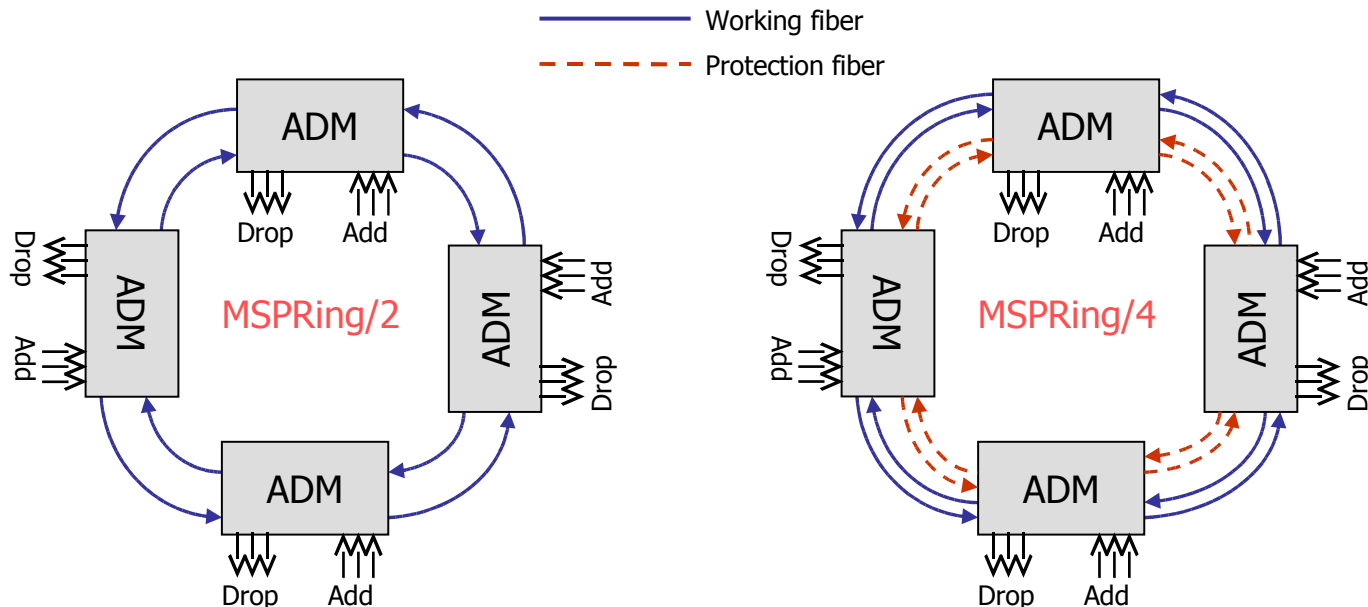

# 6. SDH Network Configuration

- ❑ DCS enable **all configurations** and **interconnection** of various configurations



Two STM-16 and three STM-1/4 DCS in Comlab, TTK

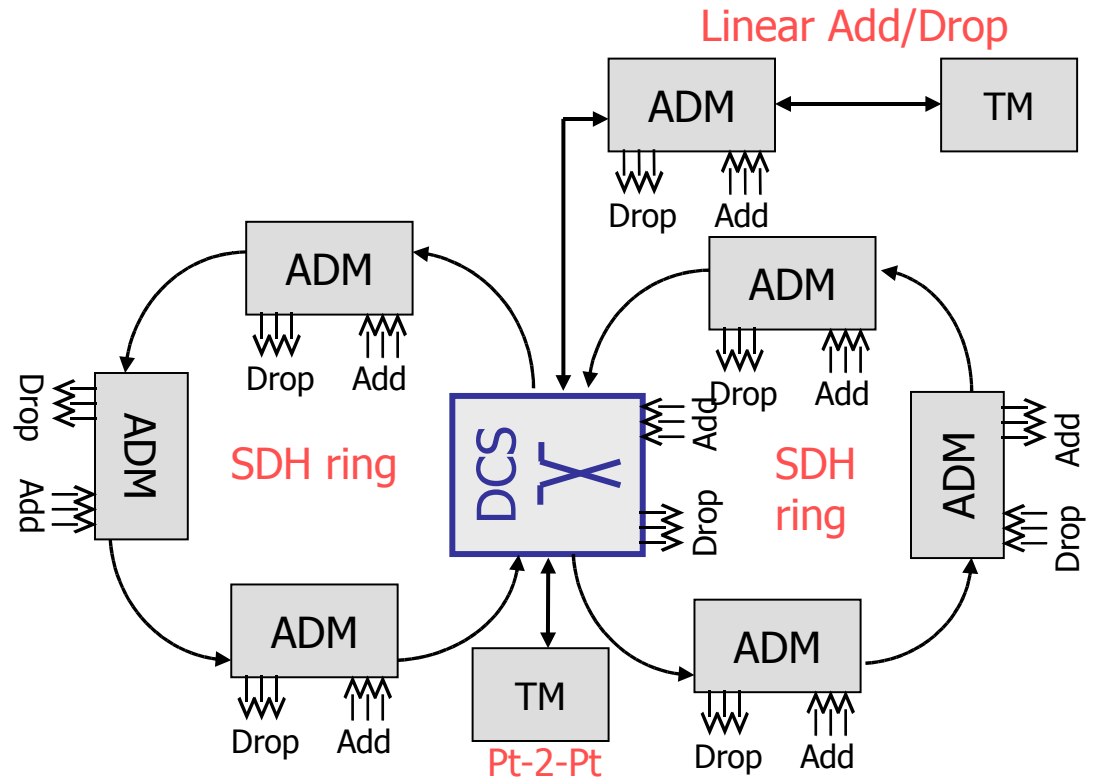

# 7. Conclusions

---

- ❑ SDH has been introduced
  - A well established optical transmission systems
  - Rich in features and well defined
- ❑ Next lecture
  - Competition from multitude of protocols and standards
  - How SDH has been modified to face the competition
  - Also a totally new optical standard coming into play

---

# Thank You!

